

1

2

3

4

Rev.A

date

Description revision

A

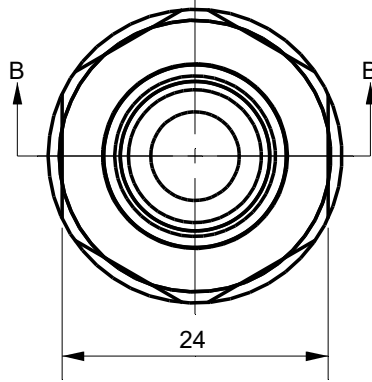

B

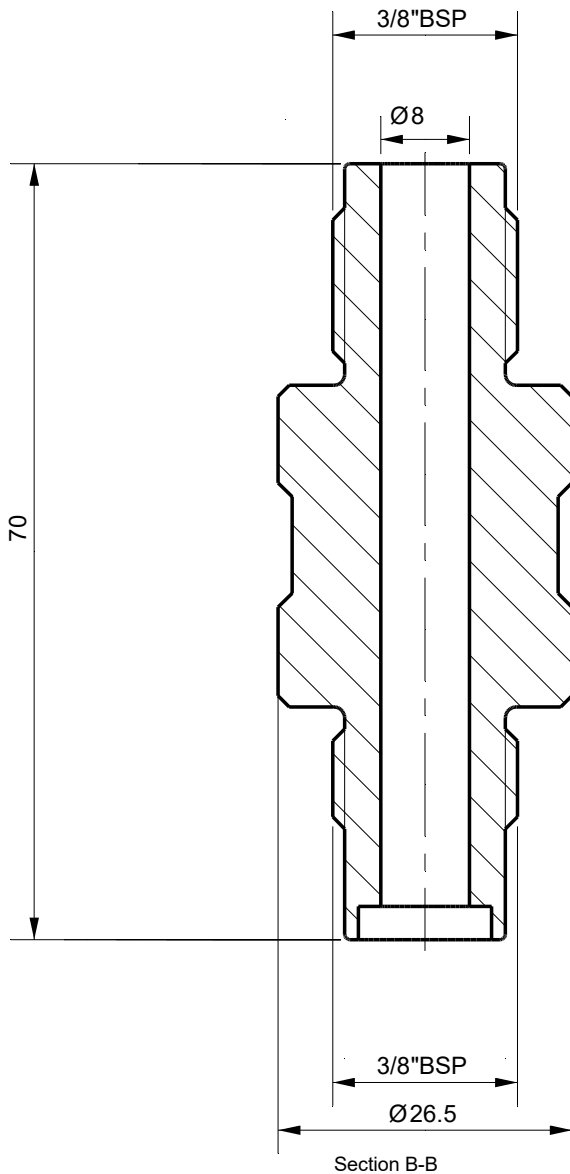

C

D

E

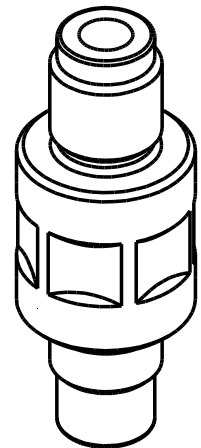
**Tolerances**

Unless Otherwise Specified  
ACC. DIN-ISO 2768 -1and 2  
Angular  $\pm 0,3^\circ$   
Corners  $<0,2 \times 45^\circ / R < 0,2$

**Finish**

-

**Material**

St.St. 316

**Dimension (No Decimals)**

0 t/m 6	6 t/m 30	30 t/m 120	120 t/m 400	400 t/m 1000
0,1	0,2	0,3	0,5	0,8

**Tolerance**

0,1

0,2

0,3

0,5

0,8

Name

Date

Remarks

Drawn

9-3-2023

Checked

**Description**

Holder for type 4/19  
 $3/8''\text{BSPM}$  1500 bar

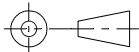
**Projection**

Drawing remains the property of  
Salomon Jetting Parts B.V.

Unit

mm

Number

**Project**

F



Salomon Jetting Parts B.V.  
Reedijk 8-1  
3274 KE Heinenoord  
www.sjpbv.com  
info@sjpbv.com  
+31 (0) 88 126 1900

Size

A4

Drawing nr.

3040068

Rev

A

Scale

1.5:1

CAD File

Sheet

1 of 1