

1

2

3

4

Rev.A date

Description revision

A

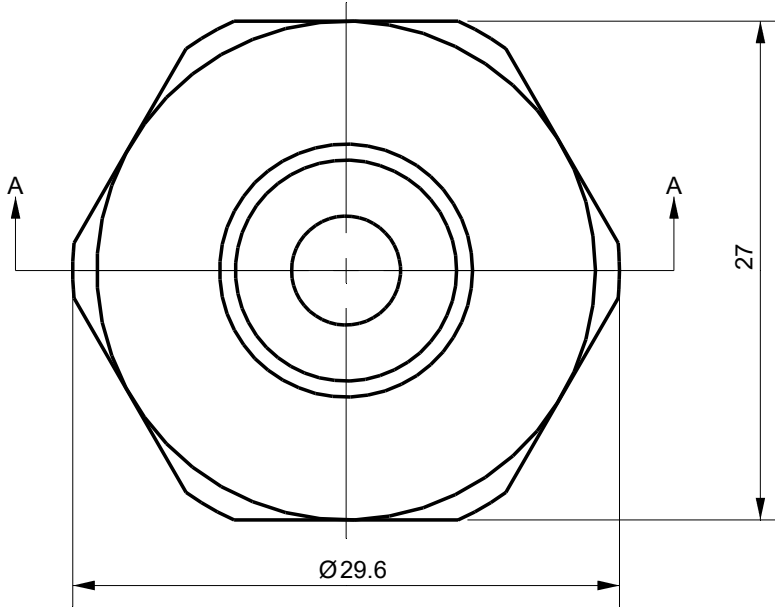

B

C

D

E

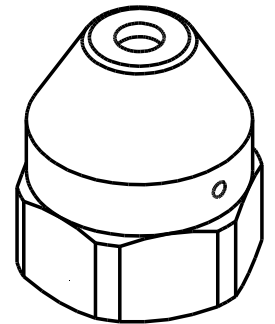
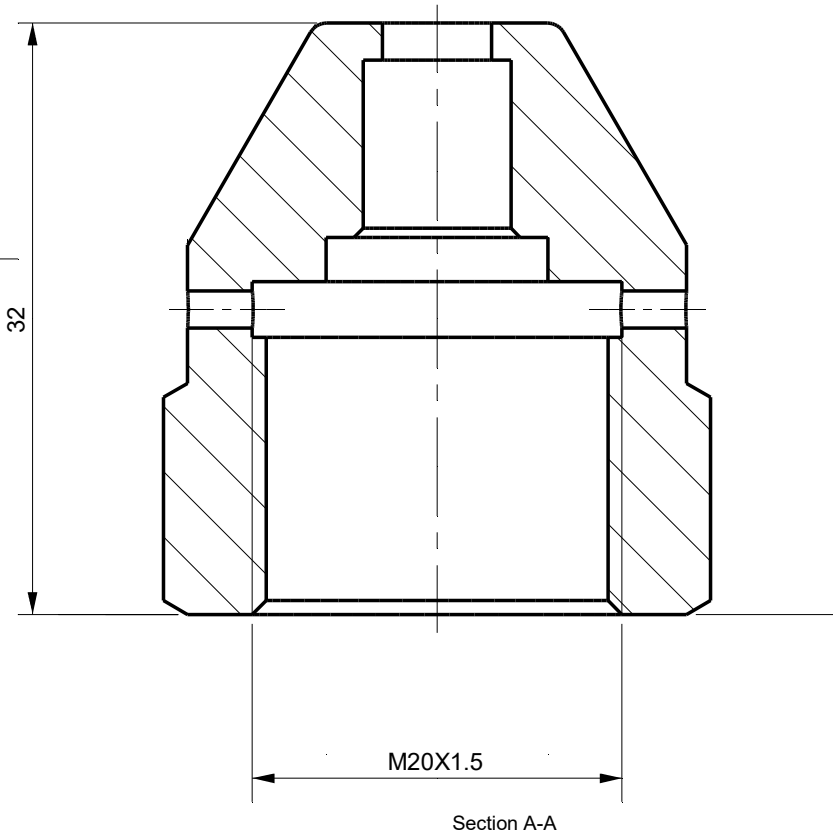
**Tolerances**

Unless Otherwise Specified
ACC. DIN-ISO 2768 -1and 2
Angular +/- 0,3°
Corners <0,2x45° / R<0,2

Finish

-

Material

St.St. 316

Dimension (No Decimals)

0 t/m 6	6 t/m 30	30 t/m 120	120 t/m 400	400 t/m 1000
0,1	0,2	0,3	0,5	0,8

Tolerance

Date

Name

Remarks

Date

Checked

Projection

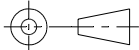

Drawing remains the property of
Salomon Jetting Parts B.V.

Unit
mm

Number

Description

Nozzle Holder Cap M20

ProjectSize
A4

Drawing nr.

01.02833-S

Rev

AScale
2.5:1

CAD File

Sheet

1 of 1

Salomon Jetting Parts B.V.
Reedijk 8-1
3274 KE Heinenoord
www.sjpbv.com
info@sjpbv.com
+31 (0) 88 126 1900

F