

1

2

3

4

Rev.A

date

Description revision

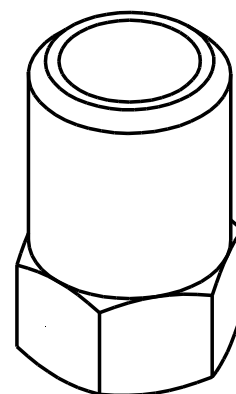
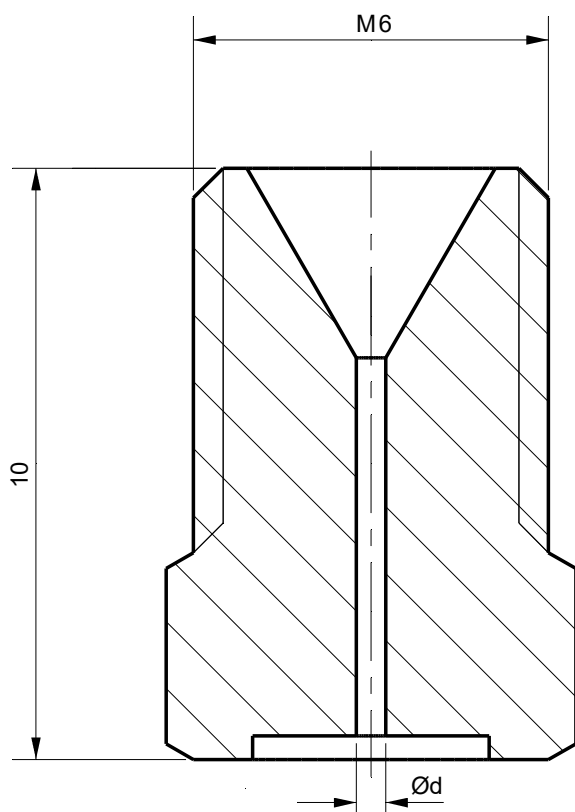
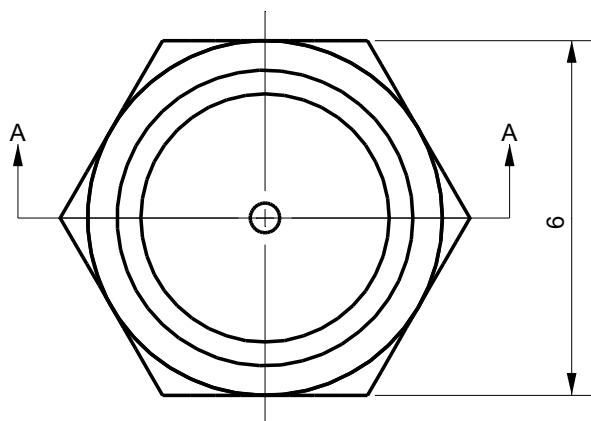
 $\text{Ød} = \text{Ø}0.5 - 0.6 - 0.7 \dots\dots\dots 3.0$

Section A-A

Tolerances

Unless Otherwise Specified
ACC. DIN-ISO 2768 -1and 2
Angular +/- 0,3°
Corners <0,2x45° / R<0,2

Finish

-

Material

St.St. 316

Dimension (No Decimals)

0 t/m 6

6 t/m 30

30 t/m 120

120 t/m 400

400 t/m 1000

Tolerance

0,1

0,2

0,3

0,5

0,8

Name**Date**

7-7-2023

Remarks**Description**

M6 Nozzle Insert
Outside hex

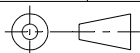
Projection

Drawing remains the property of
Salomon Jetting Parts B.V.

Unit

mm

Number**Project**

Salomon Jetting Parts B.V.
Reedijk 8-1
3274 KE Heinenoord
www.sjpbv.com
info@sjpbv.com
+31 (0) 88 126 1900

Size
A4

Drawing nr.

1567-

Rev

A

Scale
8:1

CAD File**Sheet**

1 of 1