

1

2

3

4

Rev.A

date

Description revision

A

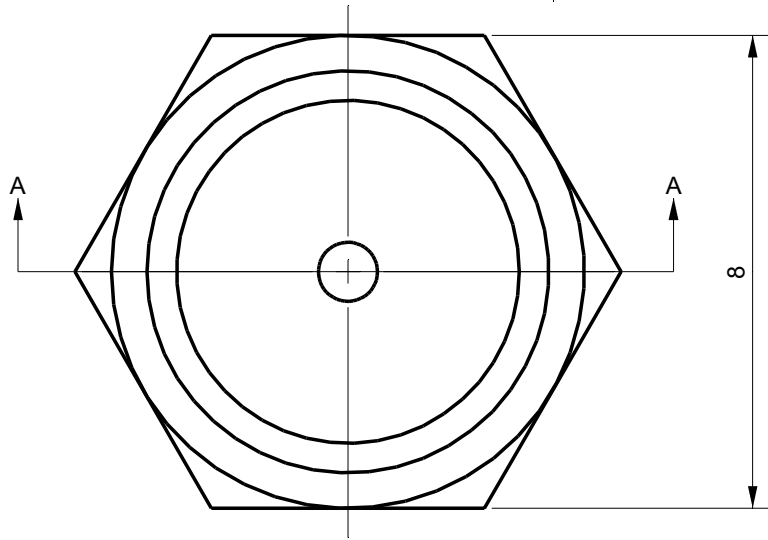

B

M8

C

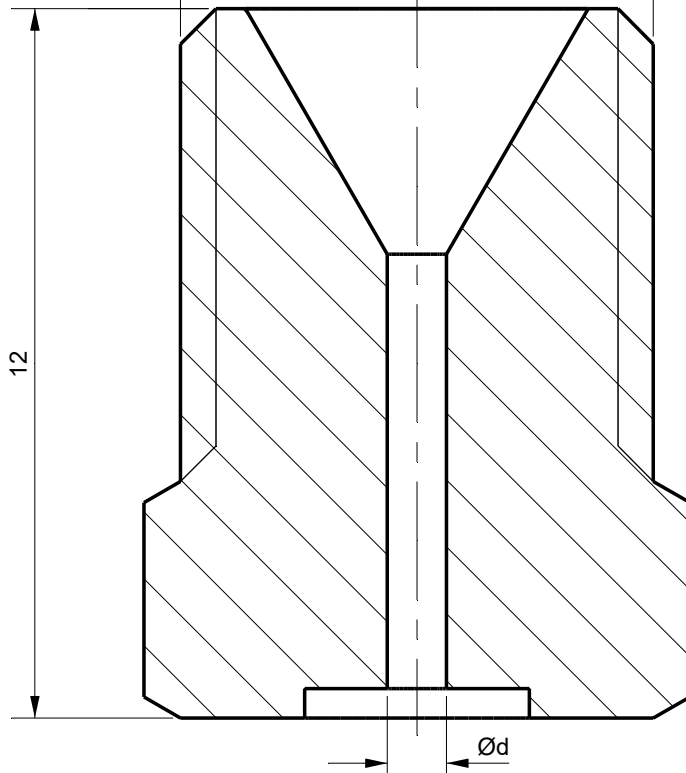

D

E

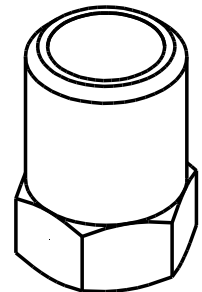
 $\text{Ød} = \text{Ø}0.5 - 0.6 - 0.7 \dots\dots\dots 3.6$ 

Section A-A

**Tolerances**

Unless Otherwise Specified  
 ACC. DIN-ISO 2768 -1and 2  
 Angular +/- 0,3°  
 Corners <0,2x45° / R<0,2

**Finish**

-

**Material**

St.St. 316

**Dimension (No Decimals)**

0 t/m 6	6 t/m 30	30 t/m 120	120 t/m 400	400 t/m 1000
---------	----------	------------	-------------	--------------

**Tolerance**

0,1	0,2	0,3	0,5	0,8
-----	-----	-----	-----	-----

**Name****Date****Remarks****Drawn**

8-1-2025

**Checked****Description**

M8 Nozzle Insert  
 Outside hex

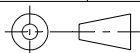
**Projection**

Drawing remains the property of  
 Salomon Jetting Parts B.V.

**Unit**

mm

**Number****Project**

F



Salomon Jetting Parts B.V.  
 Reedijk 8-1  
 3274 KE Heinenoord  
 www.sjpbv.com  
 info@sjpbv.com  
 +31 (0) 88 126 1900

Size  
**A4**

**Drawing nr.**

1568-

**Rev**

A

Scale  
**8:1**

**CAD File****Sheet**

1 of 1