

1

2

3

4

Rev.A

date

Description revision

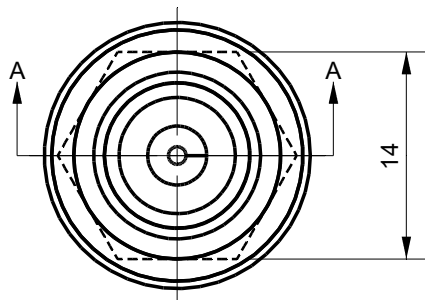

14

M18X1

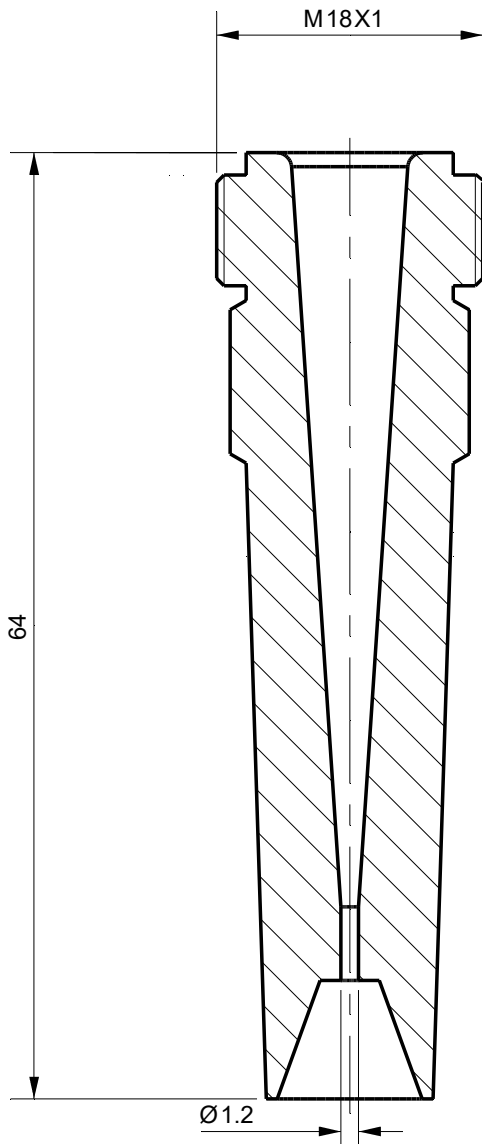

64

Ø1.2



Section A-A

Tolerances

Unless Otherwise Specified

ACC. DIN-ISO 2768 -1and 2

Angular +/- 0,3°

Corners <0,2x45° / R<0,2

Finish

Vacuum Hardening HRC 55

Material

Dimension (No Decimals)

0 t/m 6

6 t/m 30

30 t/m 120

120 t/m 400

400 t/m 1000

Tolerance

0,1

0,2

0,3

0,5

0,8

Name

Date

Remarks

Drawn

22-10-2024

Checked

Projection

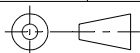

Drawing remains the property of Salomon Jetting Parts B.V.

Unit mm

Number

Project

Description

HP Longcast Nozzle
M18X1M - Ø1.2

Project



Salomon Jetting Parts B.V.

Reedijk 8-1

3274 KE Heinenoord

www.sjpbv.com

info@sjpbv.com

+31 (0) 88 126 1900

Size

A4

Drawing nr.

1963.M18.12

Rev

A

Scale

2:1

CAD File

Sheet

1 of 1