

Section B-B

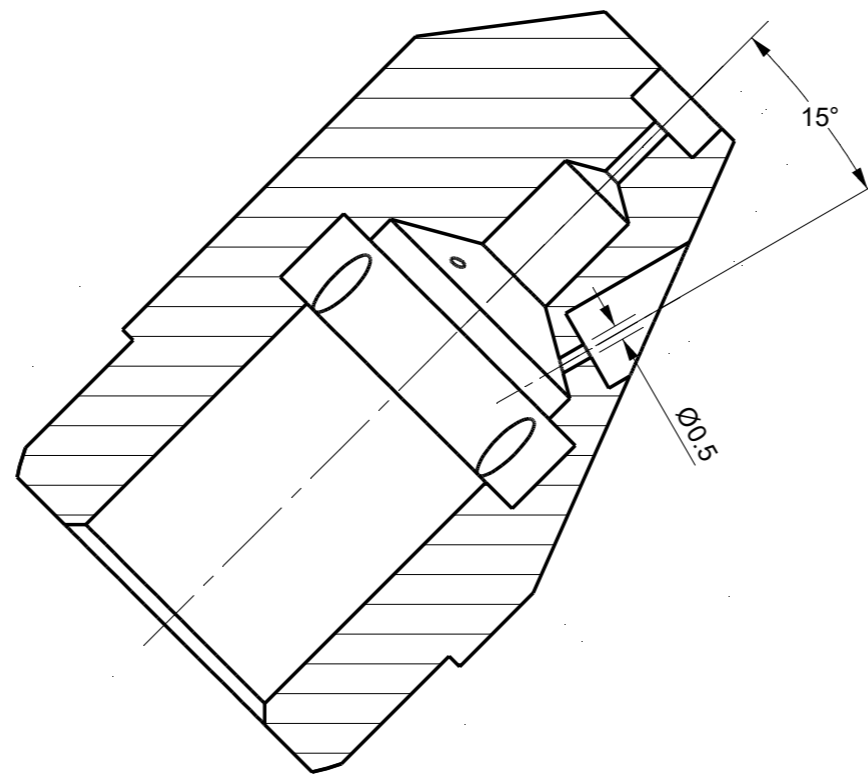

Section C-C

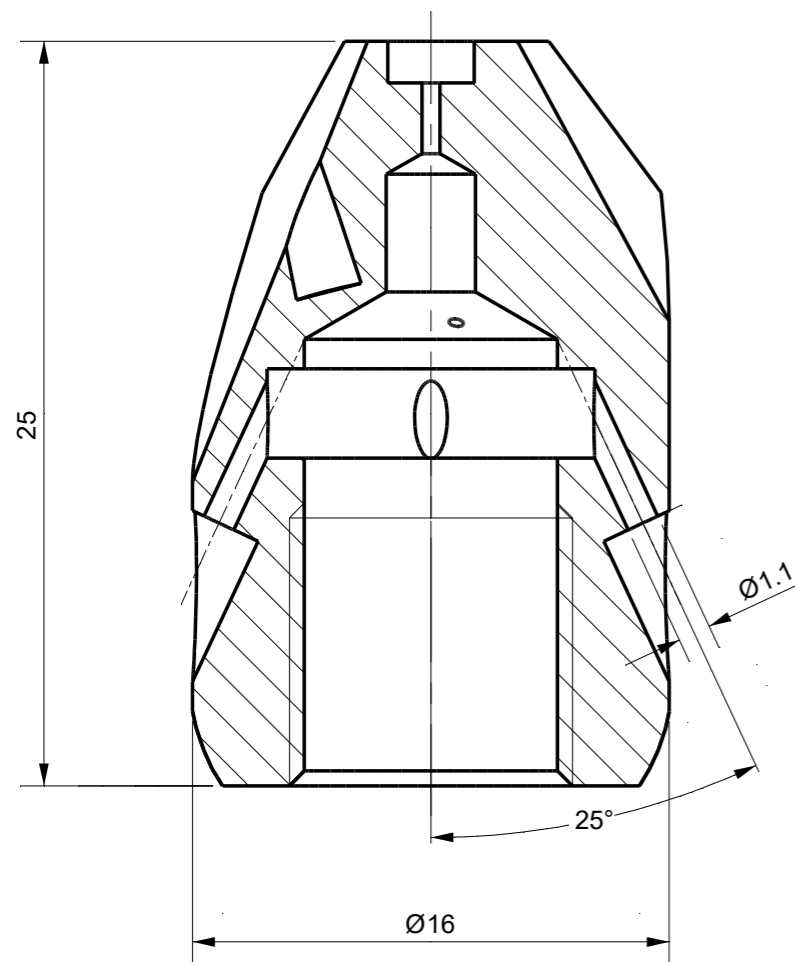
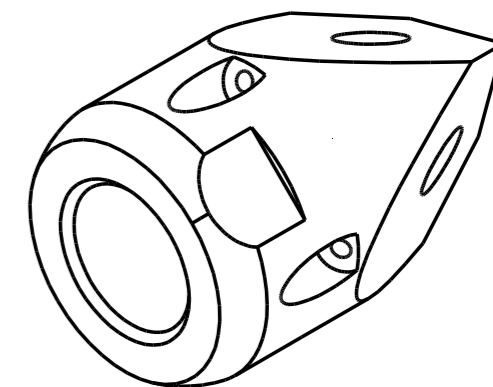

Section A-A

<b>Tolerances</b> Unless Otherwise Specified ACC. DIN-ISO 2768 -1and 2 Angular +/- 0,3° Corners <0,2x45° / R<0,2		<b>Finish</b> -					<b>Material</b> St.St. 316	
<b>Dimension (No Decimals)</b>		0 t/m 6	6 t/m 30	30 t/m 120	120 t/m 400	400 t/m 1000		
<b>Tolerance</b>		0,1	0,2	0,3	0,5	0,8		
<b>Name</b>	<b>Date</b>	<b>Remarks</b>					<b>Description</b>	
Drawn	29-9-2022						SJP Pointed Nozzle 1/8" BSP Drilled	
Checked								
<b>Projection</b>		Drawing remains the property of Salomon Jetting Parts B.V.		Unit mm	Number	<b>Project</b>		
		Salomon Jetting Parts B.V.				<b>Size</b>	<b>Drawing nr.</b>	<b>Rev</b>
		Industriestraat 17 3291 CC Strijen www.sjpbv.com info@sjpbv.com +31 (0) 88 126 1900				<b>A3</b>	<b>2-6160011</b>	<b>A</b>
		<b>Scale</b>	<b>CAD File</b>	<b>Sheet</b>		<b>1 of 1</b>		
<b>4:1</b>								