

1

2

3

4

Rev.A date Description revision

A

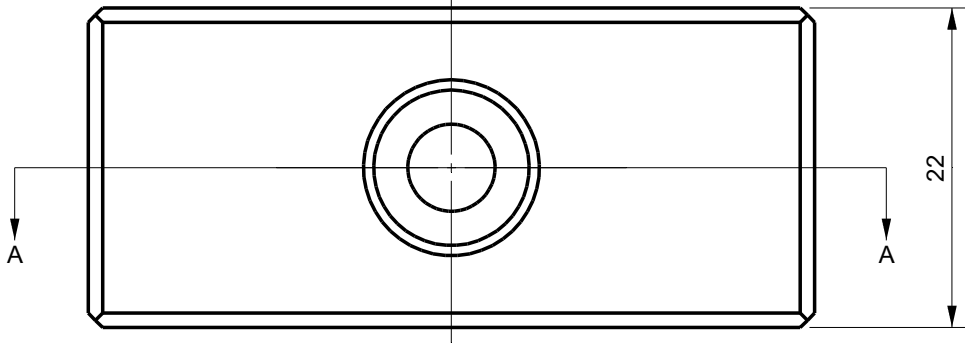

B

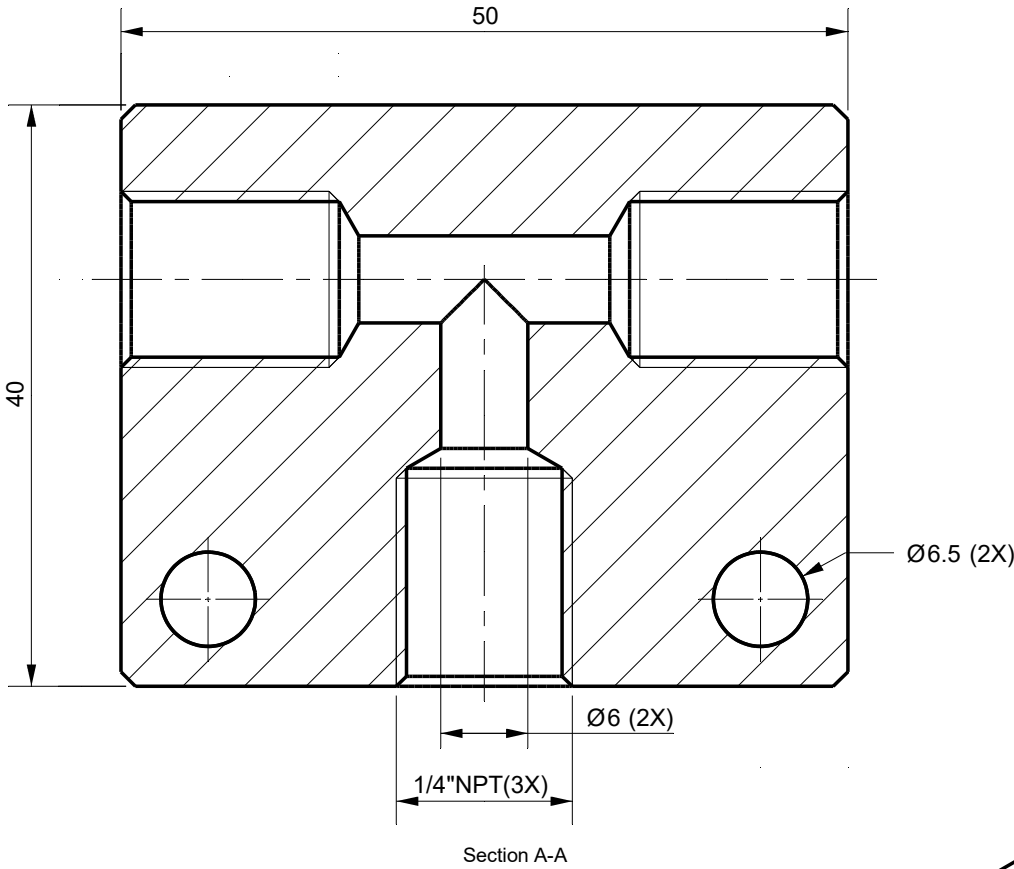

C

D

E

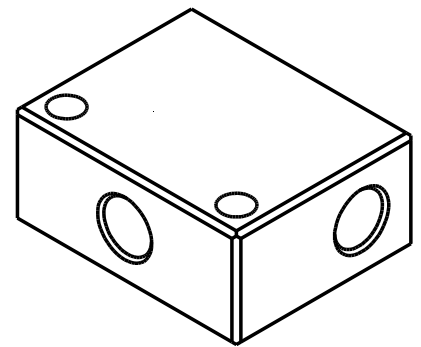

Tolerances
 Unless Otherwise Specified
 ACC. DIN-ISO 2768 -1and 2
 Angular +/- 0,3°
 Corners <0,2x45° / R<0,2

Finish	Sanding all sides in straight lines				
Dimension (No Decimals)	0 t/m 6	6 t/m 30	30 t/m 120	120 t/m 400	400 t/m 1000
Tolerance	0,1	0,2	0,3	0,5	0,8

Material
St.St. 316

Name		Remarks
Date	18-7-2024	
Drawn		

Drawing remains the property of Salomon Jetting Parts B.V.

Description
T-Coupler 1/4"NPTF

Projection	
-------------------	--

Unit: mm

Project

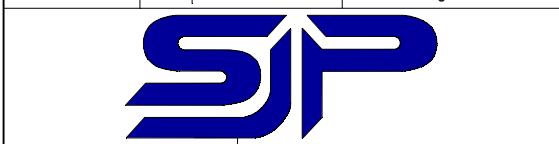

Salomon Jetting Parts B.V.
 Reedijk 8-1
 3274 KE Heinenoord
 www.sjpbv.com
 info@sjpbv.com
 +31 (0) 88 126 1900

Size	Drawing nr.	Rev
A4	20-004-002-S	A
Scale	CAD File	Sheet
2:1		1 of 1