

26

B

C

D

E

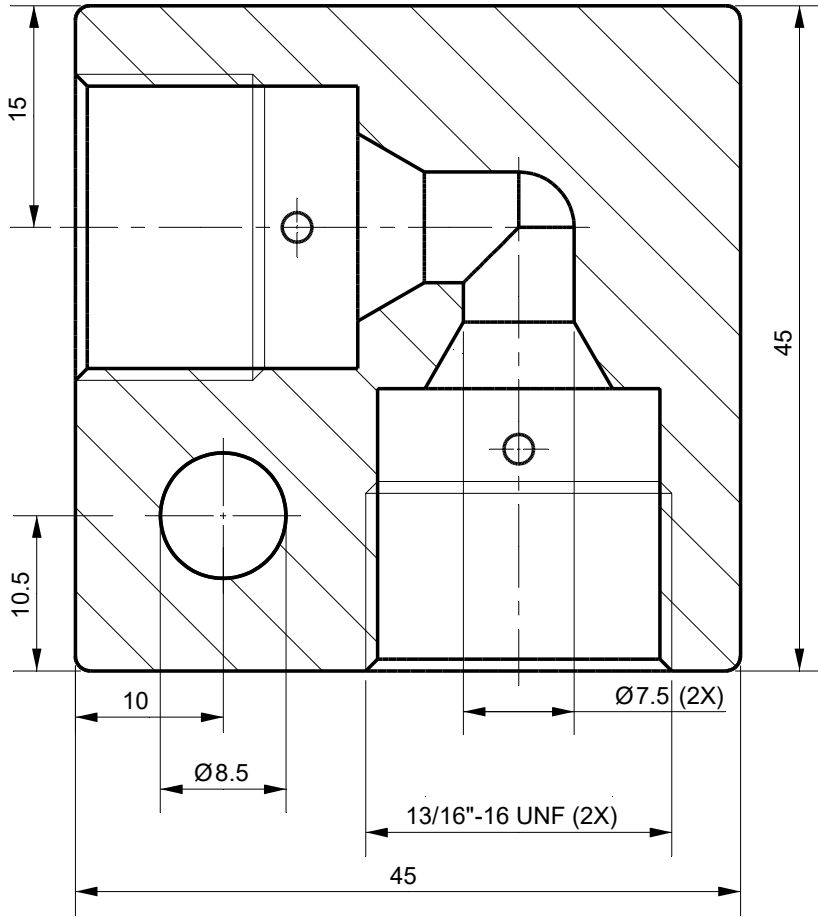

Section A-A

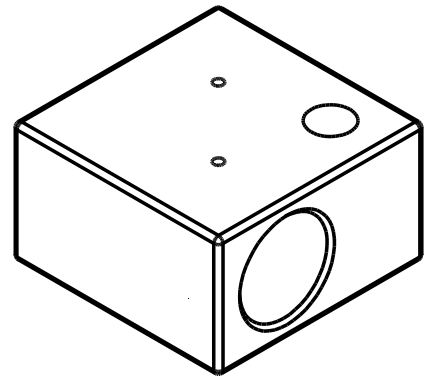

Tolerances

Unless Otherwise Specified
ACC. DIN-ISO 2768 -1 and 2
Angular +/- 0,3°
Corners <0,2x45° / R<0,2

Finish

Dimension (No Decimals)	0 t/m 6	6 t/m 30	30 t/m 120	120 t/m 400	400 t/m 1000
Tolerance	0,1	0,2	0,3	0,5	0,8

Material

St.St. 316 (1.4404)
Auto Frettagé

Name

Date

Remarks

Drawn

23-8-2022

Checked

Description

90° Block 9/16" MPF

Projection

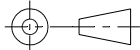

Drawing remains the property of Salomon Jetting Parts B.V.

Unit

Number

mm
Salomon Jetting Parts B.V.
Industriestraat 17
3291 CC Strijen
www.sjpbv.com
info@sjpbv.com
+31 (0) 88 126 1900

Project

Size
A4

Drawing nr.

21-009-103-S

Rev

A

Scale
2:1

CAD File

Sheet

1 of 1

