

A
B
C
D
E
F

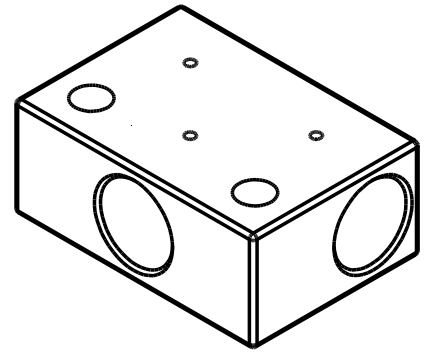
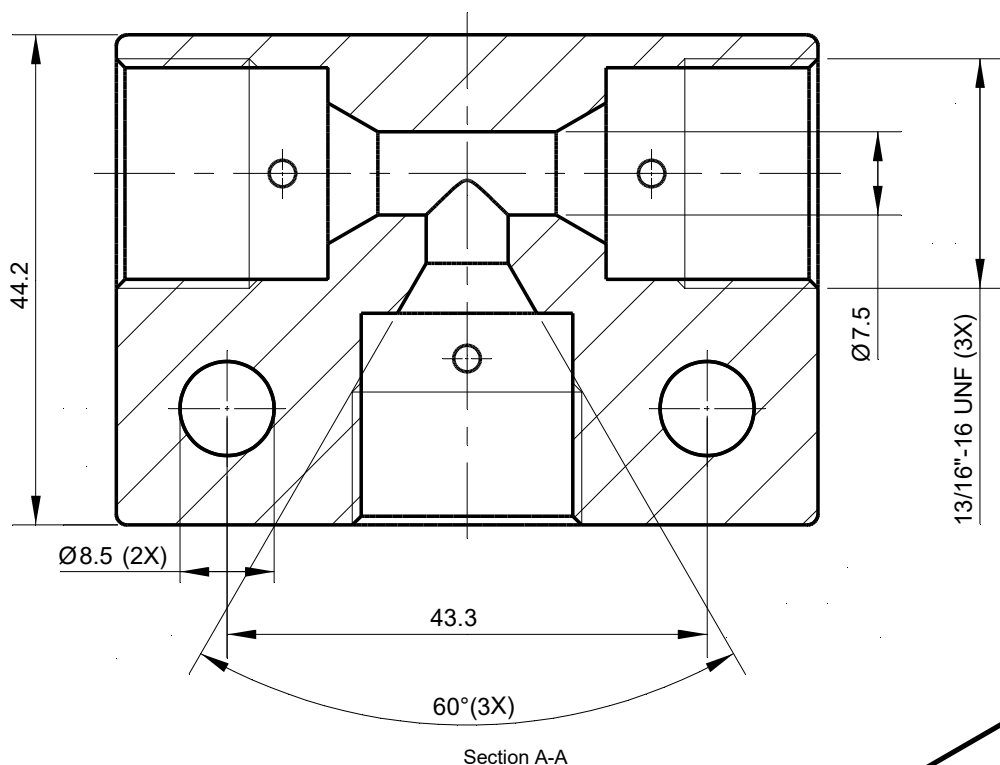
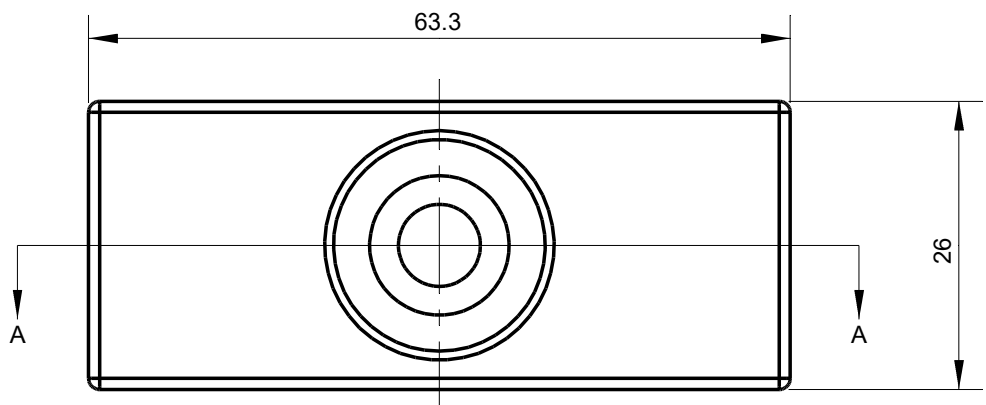

Tolerances Unless Otherwise Specified ACC. DIN-ISO 2768 -1and 2 Angular +/- 0,3° Corners <0,2x45° / R<0,2	Finish					Material St.St. 1.4404 (316L) Autofrettage	
	Dimension (No Decimals)	0 t/m 6	6 t/m 30	30 t/m 120	120 t/m 400		400 t/m 1000
Tolerance	0,1	0,2	0,3	0,5	0,8	Description T-Piece 9/16" MPF (3X)	
Name	Date 20-06-2020	Remarks			Project		
Drawn	Checked	Drawing remains the property of Salomon Jetting Parts B.V.				Size A4	Drawing nr. 21-010-103-S
Projection		Unit mm	Number	Scale 1.5:1		CAD File	Sheet 1 of 1
				Salomon Jetting Parts B.V. Industriestraat 17 3291 CC Strijen www.sjpbv.com info@sjpbv.com +31 (0) 88 126 1900			