

1

2

3

4

Rev.A	date	Description revision
Rev.B	23-10-2020	Thread end UNF adapted

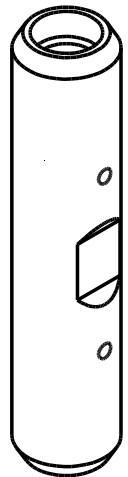
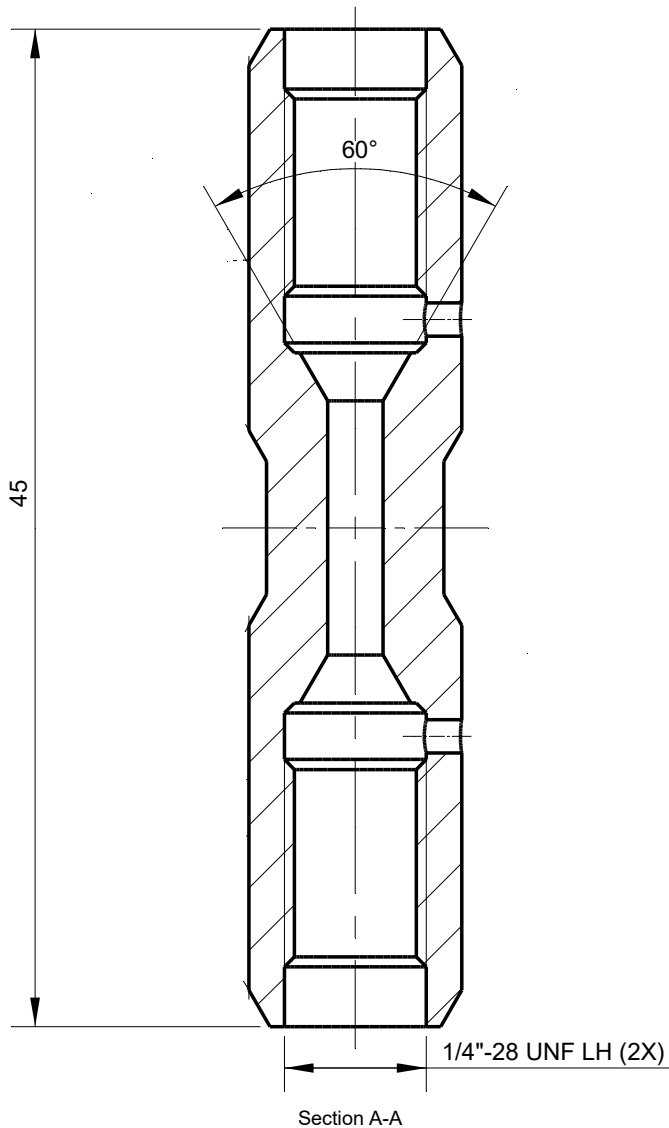
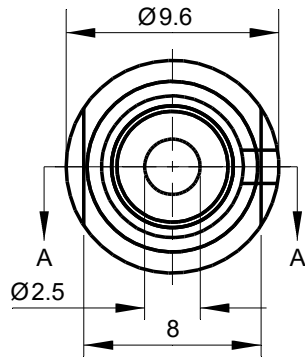

Tolerances

Unless Otherwise Specified
ACC. DIN-ISO 2768 -1and 2
Angular +/- 0,3°
Corners <math><0,2 \times 45^\circ / R<0,2</math>

Finish

Heat Treatment

Material

St.St.

Dimension (No Decimals)	0 t/m 6	6 t/m 30	30 t/m 120	120 t/m 400	400 t/m 1000
Tolerance	0,1	0,2	0,3	0,5	0,8

Name	Date	Remarks
Drawn	17-6-2020	
Checked		

Description

Lance Connector 1/4"-28 UNF LH

Projection

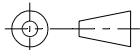

Drawing remains the property of
Salomon Jetting Parts B.V.

Unit
mm

Number

Project



Salomon Jetting Parts B.V.
Industriestraat 17
3291 CC Strijen
www.sjpbv.com
info@sjpbv.com
+31 (0) 88 126 1900

Size
A4

Drawing nr.

22-001-003-S

Rev

BScale
3:1

CAD File

Sheet

1 of 1