

1

2

3

4

Rev.A	date	Description revision
Rev.B	23-10-2020	Thread end M14 adapted

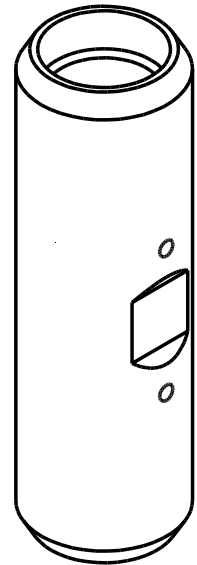
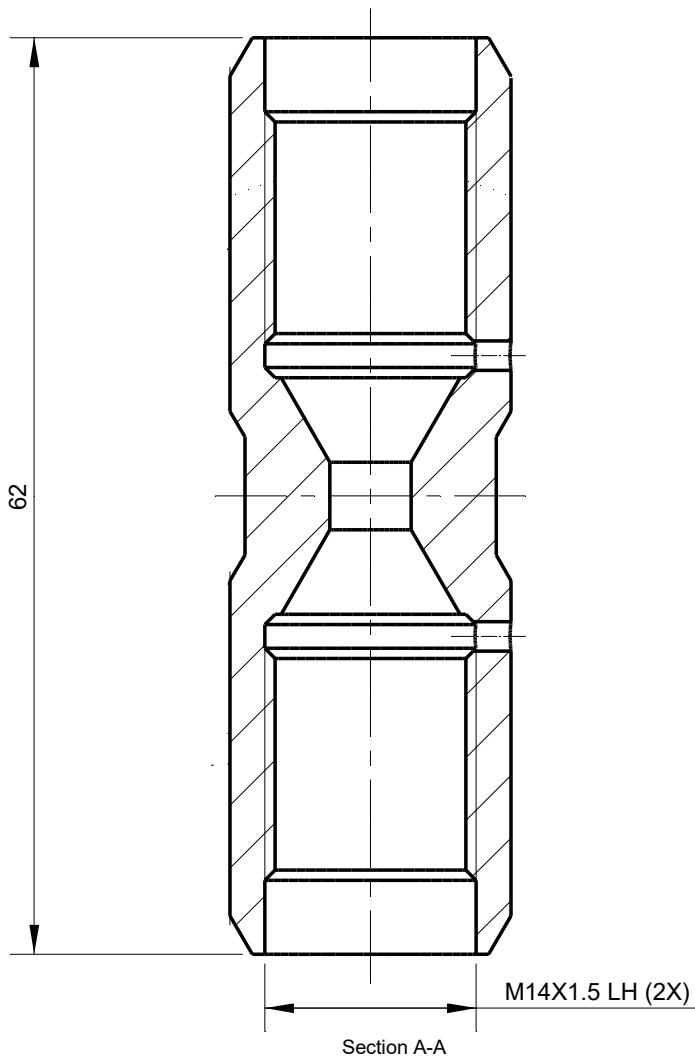
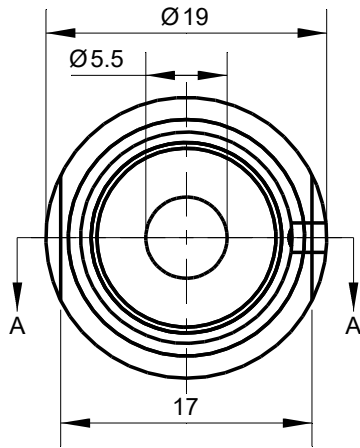

Tolerances

Unless Otherwise Specified
ACC. DIN-ISO 2768 -1and 2
Angular +/- 0,3°
Corners <0,2x45° / R<0,2

Finish

Dimension (No Decimals)	0 t/m 6	6 t/m 30	30 t/m 120	120 t/m 400	400 t/m 1000
Tolerance	0,1	0,2	0,3	0,5	0,8

Material

St.St.

Name

Name

Date

18-6-2020

Remarks

attention: left handed thread !

Description

Lance Connector M14X1.5 LH

Projection

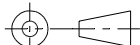

Drawing remains the property of
Salomon Jetting Parts B.V.

Unit
mm

Number

Project



Salomon Jetting Parts B.V.
Industriestraat 17
3291 CC Strijen
www.sjpbv.com
info@sjpbv.com
+31 (0) 88 126 1900

Size
A4

Drawing nr.

22-001-063-S

Rev

B

Scale
2:1

CAD File

Sheet

1 of 1