

1

2

3

4

Rev.A date

Description revision

A

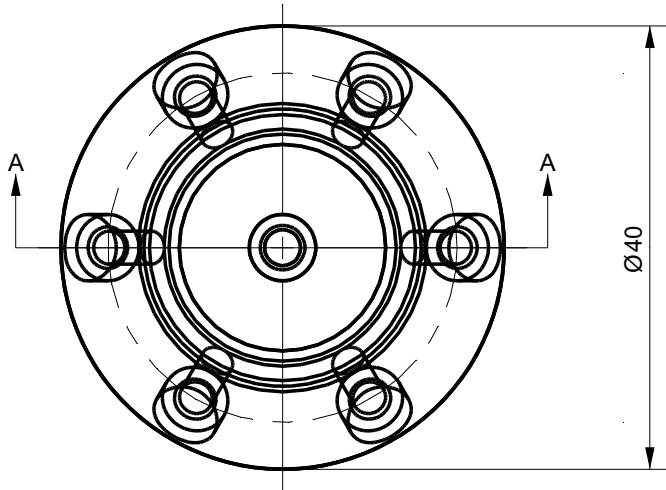

B

C

D

E

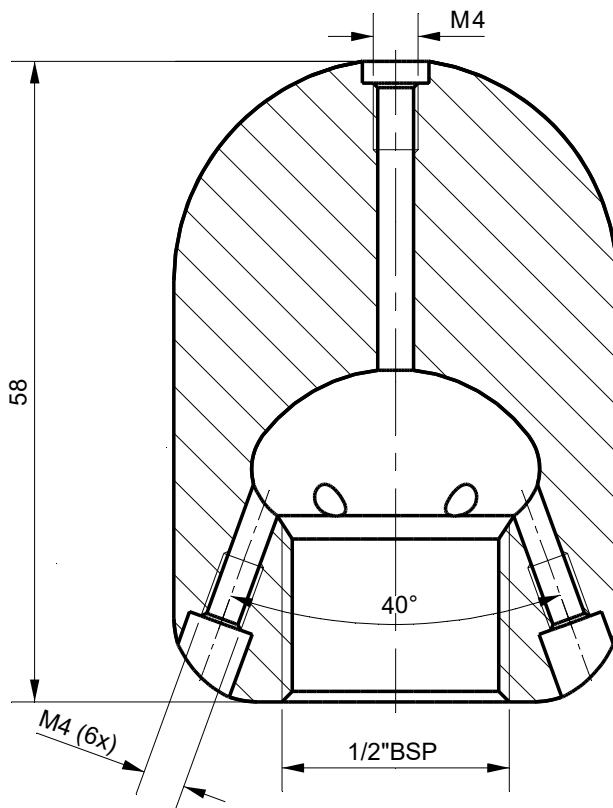

Section A-A

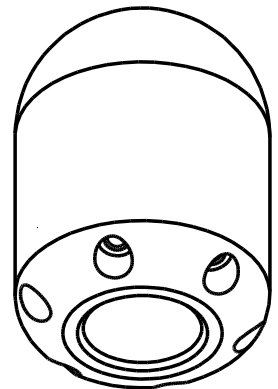
**Tolerances**

Unless Otherwise Specified
ACC. DIN-ISO 2768 -1and 2
Angular +/- 0,3°
Corners <0,2x45° / R<0,2

Finish

-

Material

St.St. 316

Dimension (No Decimals)

0 t/m 6 6 t/m 30 30 t/m 120 120 t/m 400 400 t/m 1000

Tolerance

0,1 0,2 0,3 0,5 0,8

Drawn

Name

Date

19-7-2023

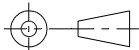
Checked**Projection****Remarks**

Drawing remains the property of
Salomon Jetting Parts B.V.

Unit

mm

Number**Description**

SJP Long nozzle
1/2"BSP w/front

Project**Size**

A4

Drawing nr.

3-6140010

Rev

A

Scale
1.5:1

CAD File**Sheet**

1 of 1



Salomon Jetting Parts B.V.
Reedijk 8-1
3274 KE Heinenoord
www.sjpbv.com
info@sjpbv.com
+31 (0) 88 126 1900