

Section B-B

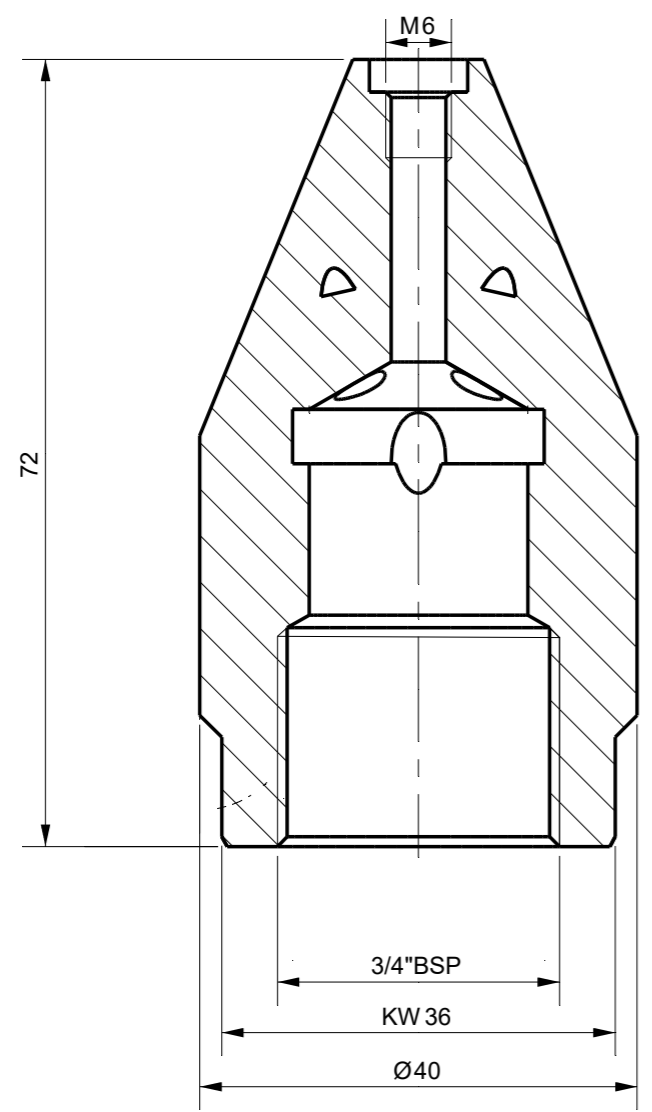

Section A-A

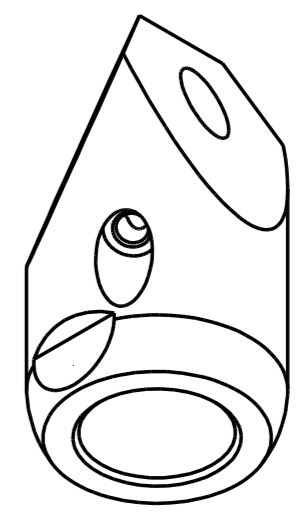

<b>Tolerances</b> Unless Otherwise Specified ACC. DIN-ISO 2768 -1and 2 Angular +/- 0,3° Corners <0,2x45° / R<0,2		<b>Finish</b> <table border="1"> <tr> <th>Dimension (No Decimals)</th> <th>0 t/m 6</th> <th>6 t/m 30</th> <th>30 t/m 120</th> <th>120 t/m 400</th> <th>400 t/m 1000</th> </tr> <tr> <td>Tolerance</td> <td>0,1</td> <td>0,2</td> <td>0,3</td> <td>0,5</td> <td>0,8</td> </tr> </table>					Dimension (No Decimals)	0 t/m 6	6 t/m 30	30 t/m 120	120 t/m 400	400 t/m 1000	Tolerance	0,1	0,2	0,3	0,5	0,8	<b>Material</b>		
Dimension (No Decimals)	0 t/m 6	6 t/m 30	30 t/m 120	120 t/m 400	400 t/m 1000																
Tolerance	0,1	0,2	0,3	0,5	0,8																
<table border="1"> <tr> <th>Name</th> <th>Date</th> <th>Remarks</th> </tr> <tr> <td>Drawn</td> <td>23-5-2023</td> <td></td> </tr> <tr> <td>Checked</td> <td></td> <td></td> </tr> </table>		Name	Date	Remarks	Drawn	23-5-2023		Checked			<b>Description</b> SJP Pointed Nozzle 3/4"BSP F w/o inserts										
Name	Date	Remarks																			
Drawn	23-5-2023																				
Checked																					
<b>Projection</b> 		Drawing remains the property of Salomon Jetting Parts B.V.			Unit mm	Number	<b>Project</b>														
		Salomon Jetting Parts B.V. Reedijk 8-1 3274 KE Heineoord www.sjpbv.com info@sjpbv.com +31 (0) 88 126 1900			Size <b>A3</b>	Drawing nr. <b>3-6160034</b>		Rev <b>A</b>													
		Scale <b>1.5:1</b>		CAD File		Sheet <b>1 of 1</b>															