

Section A-A

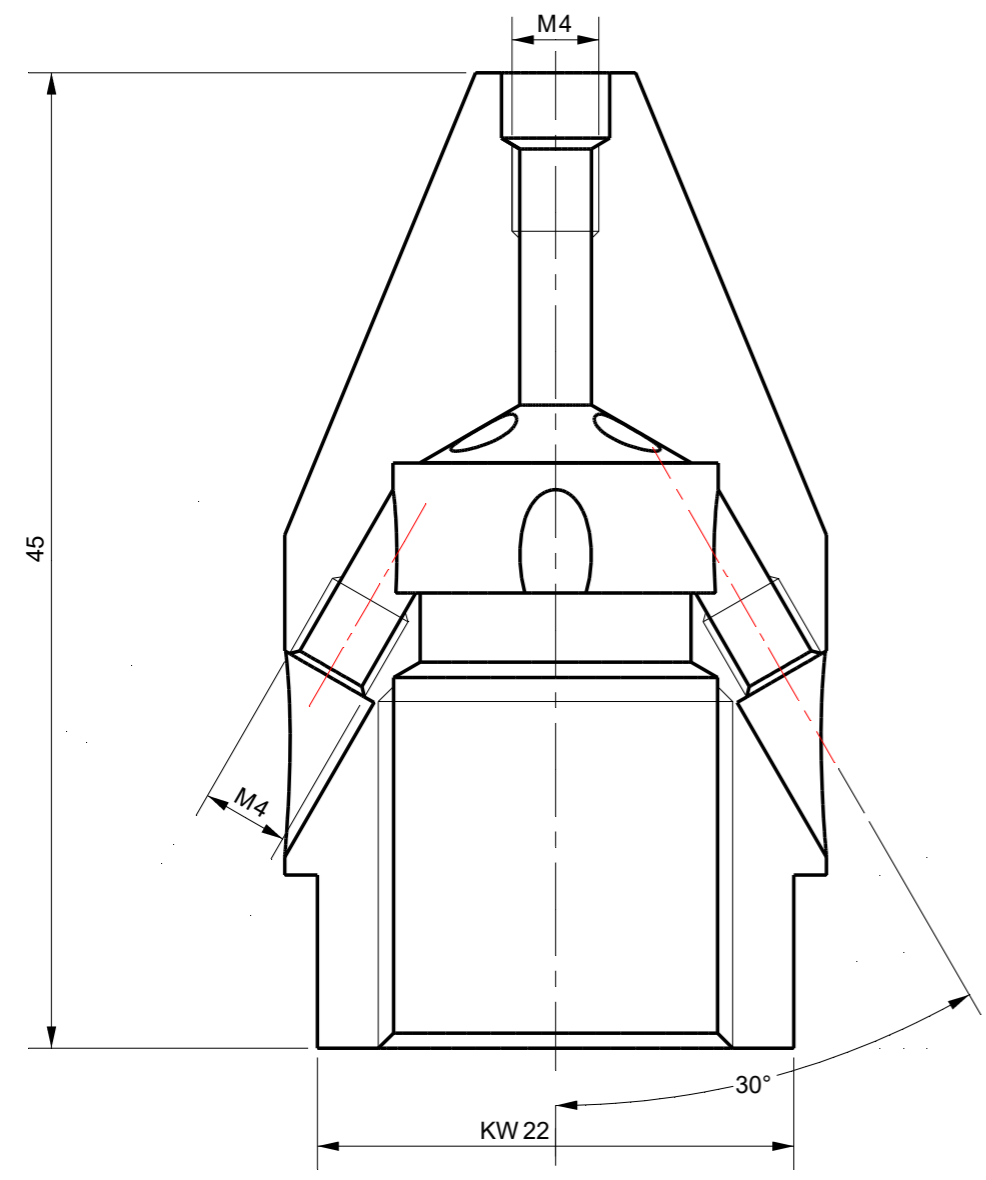
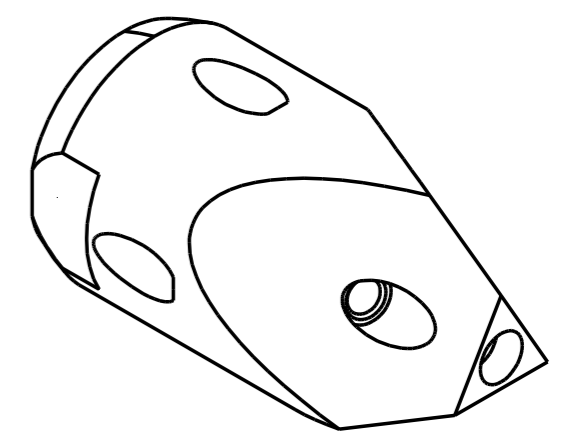

Section B-B

Tolerances Unless Otherwise Specified ACC. DIN-ISO 2768 -1en 2 Angular +/- 0,3° Corners <0,2x45° / R<0,2		Finish --					Material				
		Dimension (No Decimals)		0 t/m 6	6 t/m 30	30 t/m 120	120 t/m 400	400 t/m 1000			
		Tolerance		0,1	0,2	0,3	0,5	0,8			
Name		Date		Remarks				Description SJP Pointed Nozzle 3/8" BSP F w/inserts			
Drawn											
Checked											
Projection				Drawing remains the property of Salomon Jetting Parts B.V.				Unit mm		Number	
		Salomon Jetting Parts B.V. Industriestraat 17 3291 CC Strijen www.sjpbv.com info@sjpbv.com +31 (0) 88 126 1900				Size A3		Drawing nr. 3-6160038		Rev A	
		Scale 3:1		CAD File		Sheet 1 of 1					