

Section E-E

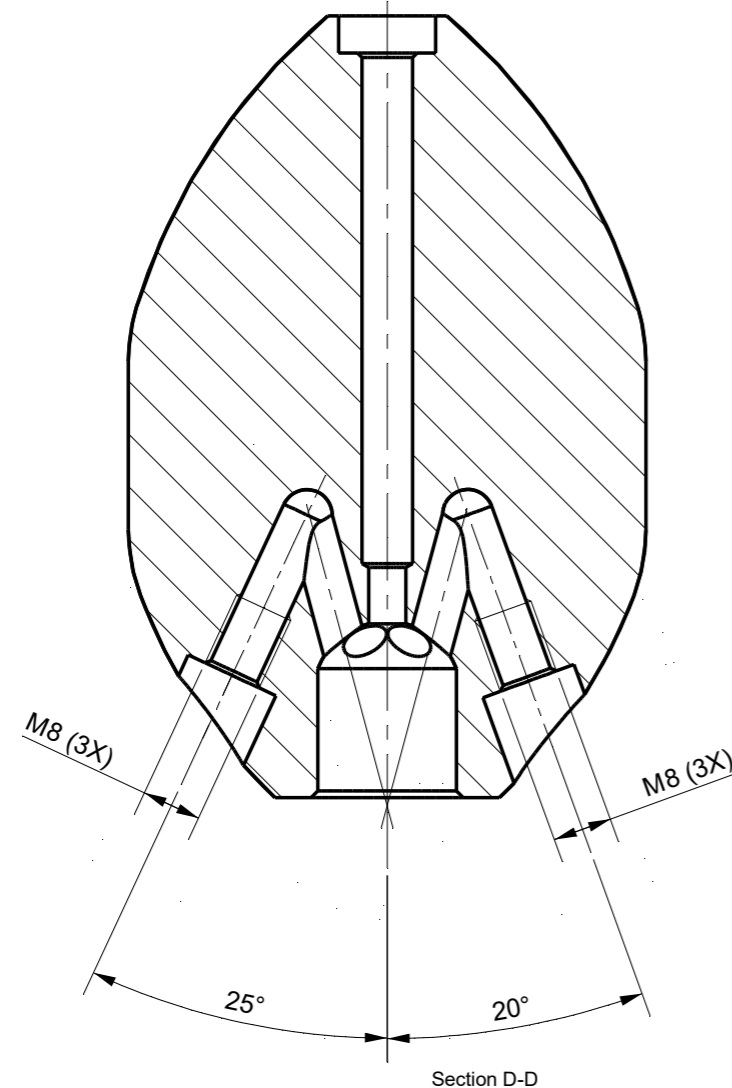

Section D-D

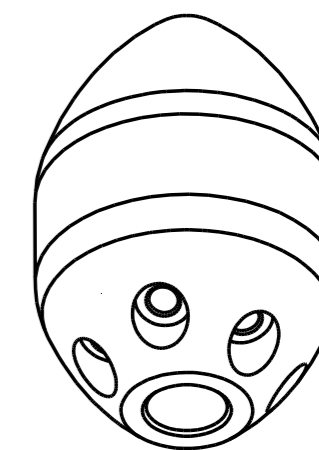

Tolerances Unless Otherwise Specified ACC. DIN-ISO 2768 -1and 2 Angular +/- 0,3° Corners <0,2x45° / R<0,2		Finish Vacuum Hardening HRC 55 Glass Head Blasting					Material 1.4034 (X46Cr13)	
Dimension (No Decimals) Tolerance		0 t/m 6	6 t/m 30	30 t/m 120	120 t/m 400	400 t/m 1000		
		0,1	0,2	0,3	0,5	0,8		
Name Drawn Checked		Date 1-3-2024		Remarks Drawing remains the property of Salomon Jetting Parts B.V.			Description Ostrich Egg Nozzle 1/2	
Projection				Unit mm		Number Project		
				Salomon Jetting Parts B.V. Reedijk 8-1 3274 KE Heinoord www.sjpbv.com info@sjpbv.com +31 (0) 88 126 1900		Size A3		Drawing nr. 3-6170010-XL
				Scale 1:1		CAD File	Rev A	
						Sheet 1 of 1		