

1

2

3

4

Rev.A

date

Description revision

A

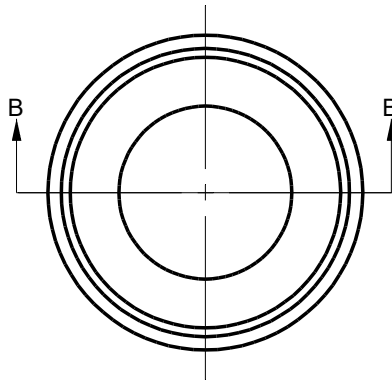

B

C

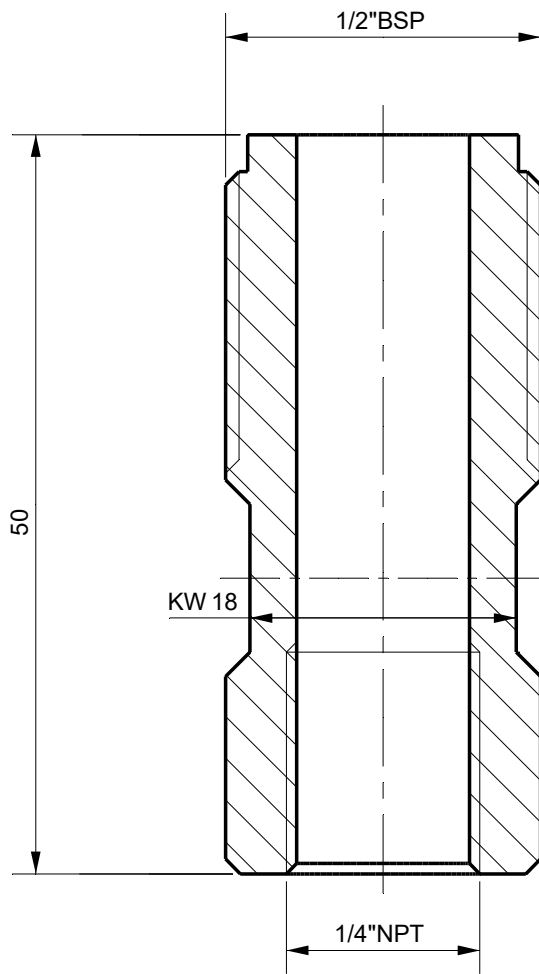

D

E

Section B-B

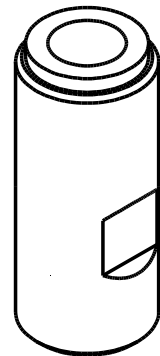
**Tolerances**

Unless Otherwise Specified
ACC. DIN-ISO 2768 -1and 2
Angular +/- 0,3°
Corners <math><0,2 \times 45^\circ / R<0,2</math>

Finish

-

Material

St.St. 304

Dimension (No Decimals)

0 t/m 6	6 t/m 30	30 t/m 120	120 t/m 400	400 t/m 1000
0,1	0,2	0,3	0,5	0,8

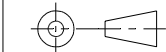
Tolerance**Projection****Name****Date**

25-7-2022

Remarks

Drawing remains the property of
Salomon Jetting Parts B.V.

Unit

mm

Number**Description**

Extension Lance
1/4"NPTF - 1/2"BSPM Flat

Project

F



Salomon Jetting Parts B.V.
Industriestraat 17
3291 CC Strijen
www.sjpbv.com
info@sjpbv.com
+31 (0) 88 126 1900

Size
A4

Drawing nr.**304357-050****Rev****A**

Scale
2:1

CAD File**Sheet****1 of 1**