

1

2

3

4

Rev.A

date

Description revision

A

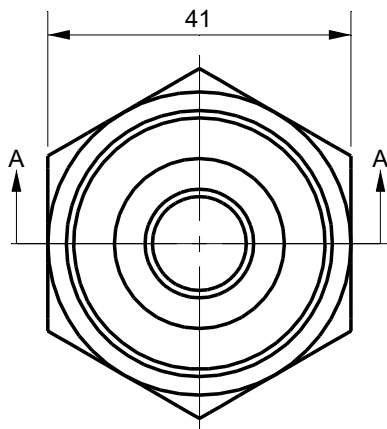

B

C

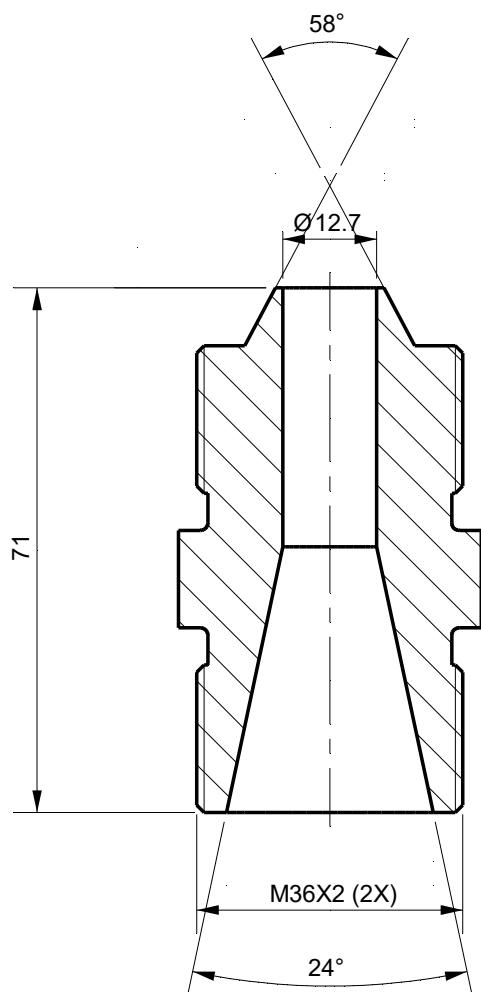

D

E

Section A-A

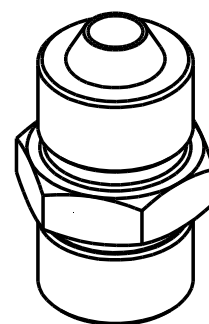
**Tolerances**

Unless Otherwise Specified
ACC. DIN-ISO 2768 -1and 2
Angular +/- 0,3°
Corners <0,2x45° / R<0,2

Finish

-

Material

St.St. 316

Dimension (No Decimals)

0 t/m 6	6 t/m 30	30 t/m 120	120 t/m 400	400 t/m 1000
0,1	0,2	0,3	0,5	0,8

Tolerance

-

Description

Adapter M36X2 - M36X2 Cone 1500 bar

Name**Date**

26-1-2022

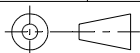
Remarks**Drawn****Checked****Projection**

Drawing remains the property of
Salomon Jetting Parts B.V.

Unit
mm

Number

Project

F



Salomon Jetting Parts B.V.
Industriestraat 17
3291 CC Strijen
www.sjpbv.com
info@sjpbv.com
+31 (0) 88 126 1900

Size
A4

Drawing nr.

304380

Rev

AScale
1:1

CAD File

Sheet

1 of 1