

Section A-A

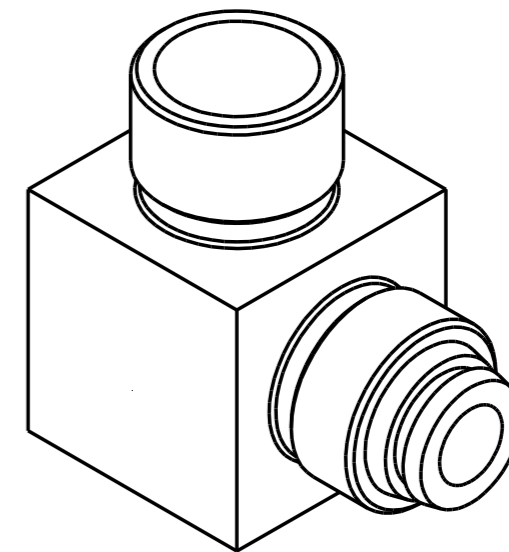

Tolerances Unless Otherwise Specified ACC. DIN-ISO 2768 -1 and 2 Angular +/- 0,3° Corners <0,2x45° / R<0,2		Finish --					Material St. St. 316		
Dimension Tolerance		0 t/m 6	6 t/m 30	30 t/m 120	120 t/m 400	400 t/m 1000	Description Block 90° M36X2 L/R W/O Plug 1500 bar base		
		0,1	0,2	0,3	0,5	0,8	Project		
Name Drawn Checked Projection		Date 10-9-2019	Remarks Drawing remains the property of Salomon Jetting Parts B.V.			Unit mm	Number	Size A3 Scale 1.5:1	
		Salomon Jetting Parts B.V. Industriestraat 17 3291 CC Strijen www.sjpbv.com info@sjpbv.com +31 (0) 88 126 1900					Drawing nr. 304401	Rev A	Sheet 1 of 1