

1

2

3

4

A

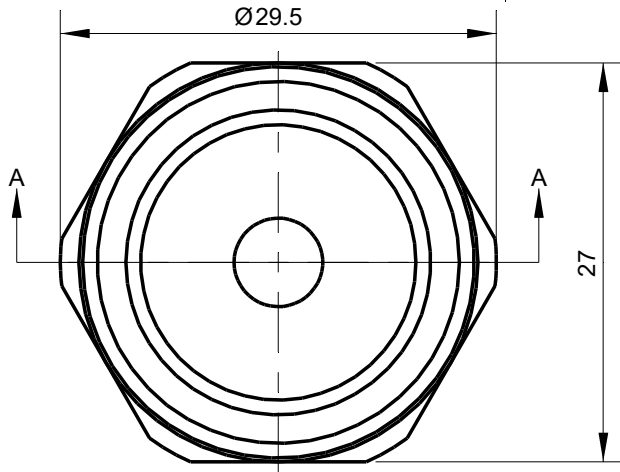

B

C

D

E

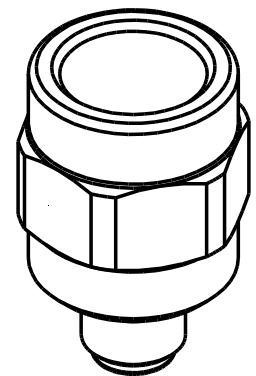
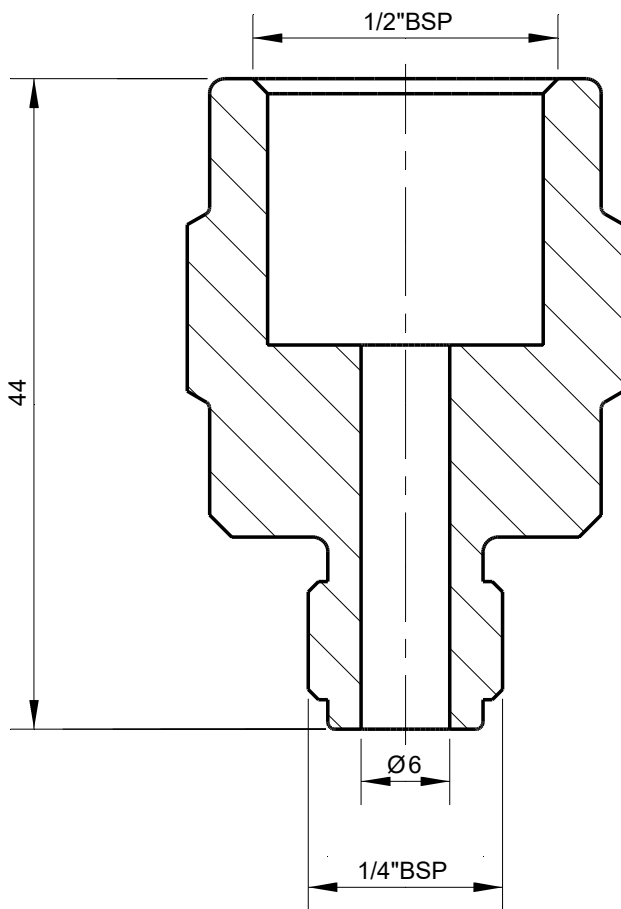

Section A-A

Tolerances

Unless Otherwise Specified
ACC. DIN-ISO 2768 -1and 2
Angular +/- 0,3°
Corners <0,2x45° / R<0,2

Finish

-

Material

St.St. 316

Dimension (No Decimals)

0 t/m 6 6 t/m 30 30 t/m 120 120 t/m 400 400 t/m 1000

Tolerance

0,1 0,2 0,3 0,5 0,8

Name**Date**

13-3-2020

Remarks**Description**

Holder 1/4\"/>

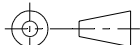
Projection

Drawing remains the property of
Salomon Jetting Parts B.V.

Unit
mm

Number

Project

Salomon Jetting Parts B.V.
Industriestraat 17
3291 CC Strijen
www.sjpbv.com
info@sjpbv.com
+31 (0) 88 126 1900

Size
A4

Drawing nr.

304969

Rev

AScale
2:1

CAD File

Sheet

1 of 1