

1

2

3

4

Rev.A

date

Description revision

A

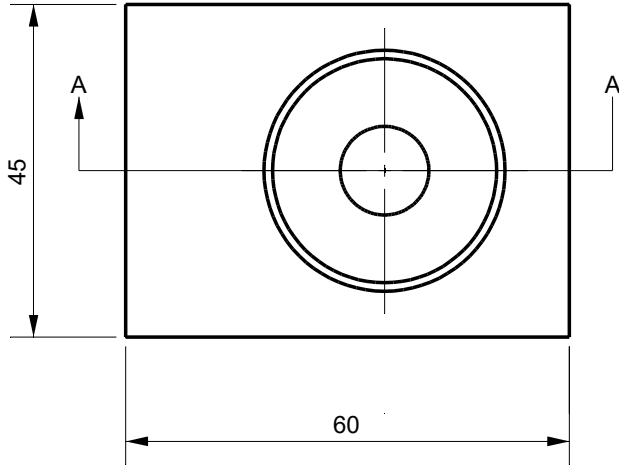

B

C

D

E

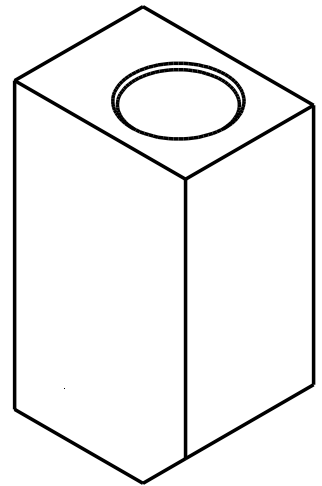
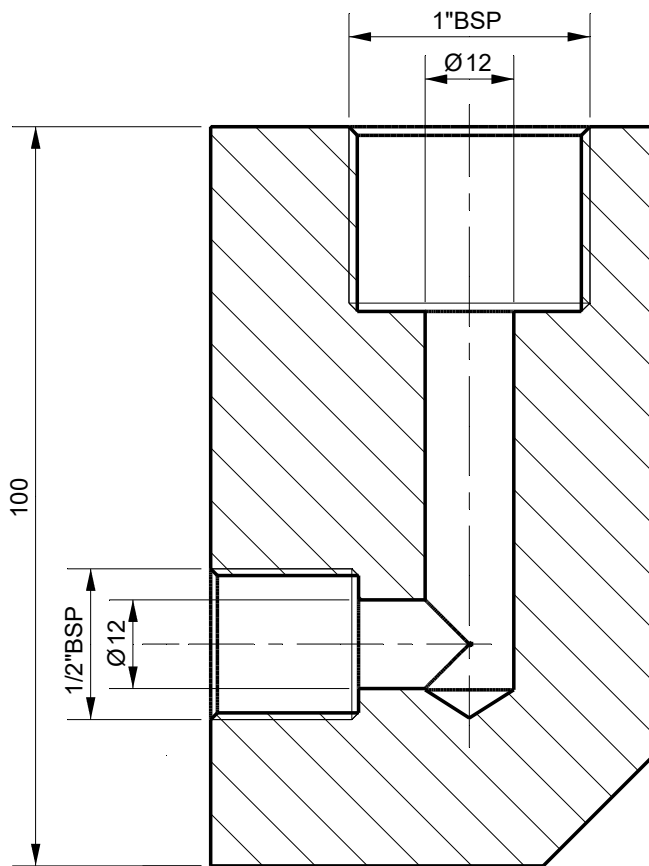

Section A-A

**Tolerances**

Unless Otherwise Specified  
ACC. DIN-ISO 2768 -1and 2  
Angular +/- 0,3°  
Corners <0,2x45° / R<0,2

**Finish**

-

**Material**

St.St. 316

**Dimension (No Decimals)**

0 t/m 6    6 t/m 30    30 t/m 120    120 t/m 400    400 t/m 1000

**Tolerance**

0,1    0,2    0,3    0,5    0,8

Name

Date

Remarks

Drawn

14-7-2022

Checked

Projection

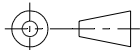
Drawing remains the property of  
Salomon Jetting Parts B.V.Unit  
mm

Number

Project

Description

90° Block

F



Salomon Jetting Parts B.V.  
Industriestraat 17  
3291 CC Strijen  
www.sjpbv.com  
info@sjpbv.com  
+31 (0) 88 126 1900

Size  
**A4**

Drawing nr.

**3082792-S**

Rev

**A**Scale  
**1:1**

CAD File

Sheet

**1 of 1**