

Section B-B

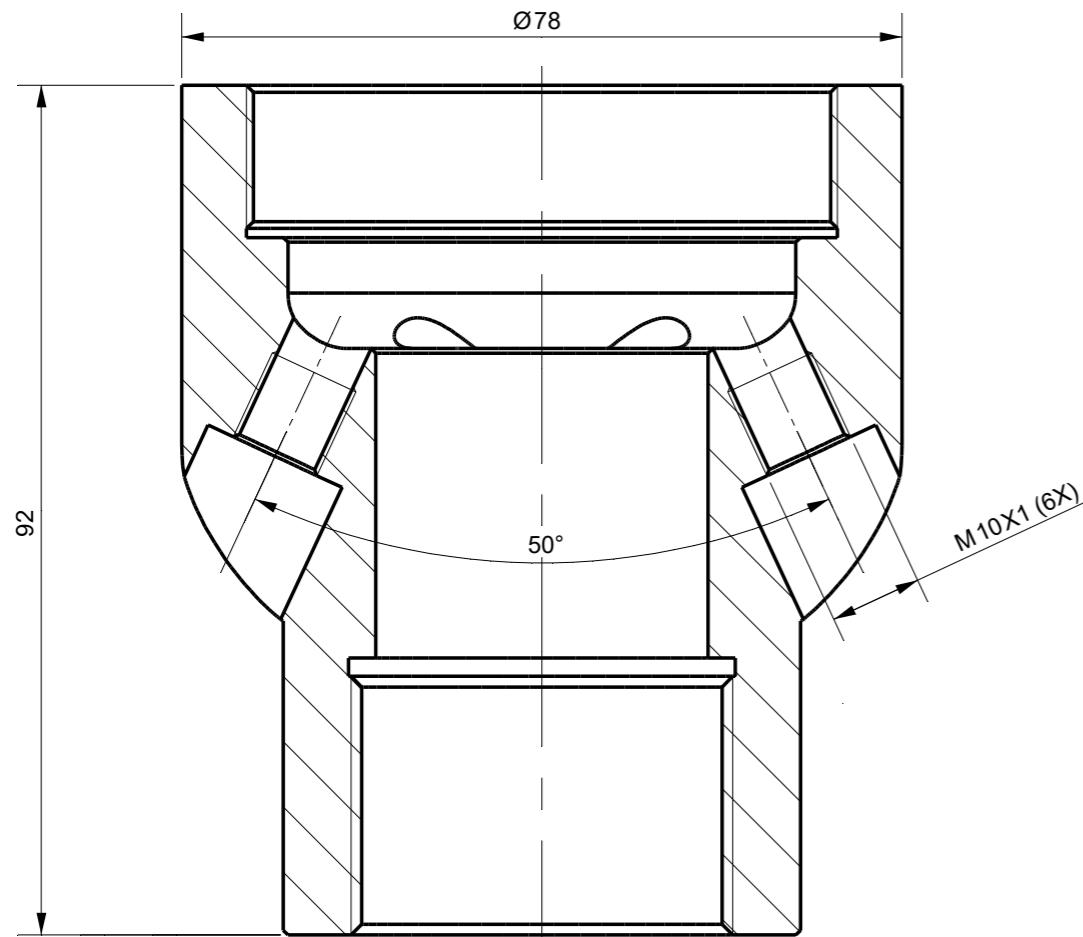
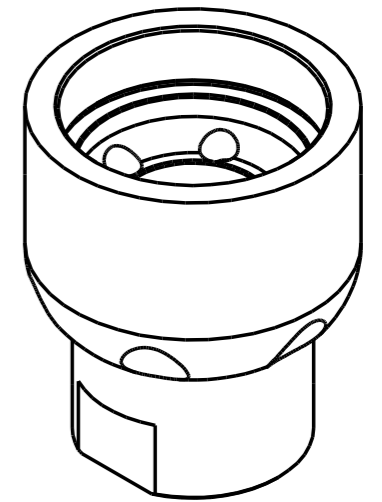

Section A-A

| Tolerances Unless Otherwise Specified ACC. DIN-ISO 2768 -1 and 2 Angular +/- 0,3° Corners <0,2x45° / R<0,2 | | Finish <table border="1"> <tr> <th>Dimension (No Decimals)</th> <th>0 t/m 6</th> <th>6 t/m 30</th> <th>30 t/m 120</th> <th>120 t/m 400</th> <th>400 t/m 1000</th> </tr> <tr> <td>Tolerance</td> <td>0,1</td> <td>0,2</td> <td>0,3</td> <td>0,5</td> <td>0,8</td> </tr> </table> | | | | | Dimension (No Decimals) | 0 t/m 6 | 6 t/m 30 | 30 t/m 120 | 120 t/m 400 | 400 t/m 1000 | Tolerance | 0,1 | 0,2 | 0,3 | 0,5 | 0,8 | Material | |
|--|-----------|---|------------|------------------------|-------------------|-------------------------------|-------------------------|---------|----------|------------|---|--------------|-----------|-----|-----|-----|-----|-----|-----------------|--|
| Dimension (No Decimals) | 0 t/m 6 | 6 t/m 30 | 30 t/m 120 | 120 t/m 400 | 400 t/m 1000 | | | | | | | | | | | | | | | |
| Tolerance | 0,1 | 0,2 | 0,3 | 0,5 | 0,8 | | | | | | | | | | | | | | | |
| <table border="1"> <tr> <th>Name</th> <th>Date</th> <th>Remarks</th> </tr> <tr> <td>Drawn</td> <td>17-2-2023</td> <td></td> </tr> <tr> <td>Checked</td> <td></td> <td></td> </tr> </table> | | Name | Date | Remarks | Drawn | 17-2-2023 | | Checked | | | Description <h2 style="text-align: center;">Pointed Nozzle</h2> | | | | | | | | | |
| Name | Date | Remarks | | | | | | | | | | | | | | | | | | |
| Drawn | 17-2-2023 | | | | | | | | | | | | | | | | | | | |
| Checked | | | | | | | | | | | | | | | | | | | | |
| Projection | | Drawing remains the property of Salomon Jetting Parts B.V. | | | Unit mm | Number | Project | | | | | | | | | | | | | |
| | | Salomon Jetting Parts B.V. Reedijk 8-1 3274 KE Heinenoord www.sjpbv.com info@sjpbv.com +31 (0) 88 126 1900 | | | Size A3 | Drawing nr. 3907-S1 | Rev A | | | | | | | | | | | | | |
| | | Scale 1.25:1 | CAD File | Sheet 1 of 1 | | | | | | | | | | | | | | | | |