



P.A. - S.r.l. - EQUIPAGGIAMENTI TECNICI DEL LAVAGGIO

VIA MILANO, 13 - 42048 RUBIERA (REGGIO EMILIA) - ITALY - Tel. +39 0522 623611 (10 linee)
 Fax +39 0522 629600 - R.E.A. RE 156319 - Registro Imprese RE 11535 - Mecc. RE 013446
 C.F. e P. IVA 01035950359 - Cap. Soc. i.v. € 1.560.000,00 - Codice Identificativo C.E.E. IT 01035950359
 ART. 2497 - BIS C.C. DIREZIONE E COORDINAMENTO BENETTI srl R.I. TRIB. DI RE 01480690351
 http://www.pa-etl.it - E-mail: info@pa-etl.it

GRUPPO BANCO POPOLARE DI VERONA E NOVARA SWIFT VRBPIT2V492



VB 9 – Unloader valve with micro switch

Technical manual: **E 227**

Pressure regulating unloader valve connected to an electric switch, electro-mechanic type, which when reaching a preset calibrated pressure, opens or closes an electric contact.

At gun shut off, the water flow is bypassed at reduced pressure.

DN 10



- **60.2350.00** VB 9 w/micro G3/8 FF

- Sturdy steel and brass construction.
- Electrical insulation: class IP55
- Electric drive shunted from valve functions with two positions:
 - 1) Unloader working in pressure
 - 2) Unloader with all the flow in bypass
- Mechanical control of the electric switch for a simple and reliable function.
- Hexagonal shaped check valve to avoid jamming.
- Version with knob, fitted with locknut for min. and max. pressure regulation.

Technical specifications

Part Number	Rated pressure bar - MPa	Permissible pressure bar - MPa	Minimum adjustable pressure bar - MPa	Max. flow rate: 30 l/min. Max temperature: 90°C (1)		Inlet Outlet bypass	Weight g
				(2)Trapped pressure at circuit closure %	(3)Pressure drop to reset bypass %		
60.2350.00	220 - 22	250 - 25	22 – 2.2	13	71	G3/8MF	1000

(1) The valve has been designed for a continuous use at a water temperature of 60°C. It can resist for short periods at a maximum temperature of 90°C.

(2) This is the maximum pressure increase implemented in the circuit for the intervention of the valve and to bring all the fluid in bypass (percentage figures of the pressure set up)

(3) This is the pressure reduction necessary in comparison to the set up, in order that the valve brings back pressure in the circuit. (percentage figures of the pressure set up)

TECHNICAL SPECIFICATIONS OF THE MICRO SWITCH

Max rated voltage:	250 V
Breaking switch:	6 (A) – resistive load - 2 (A) – inductive load
Cable length :	1000 mm – electric wire : 3 x 0.75 mm ²
environment temperature:	75 °C – Type of action: 1C
Electrical component life:	50.000 commutations, T.85°C, a 250V in line with CEE 24- VDE 0630
Pollution situation of the device control:	High

Instruction manual, maintenance, installation, spare parts

For a correct utilization, follow the directions of this manual

Re-print them on the use and Maintenance booklet of the machine.

n. 12.9227.00

DIMENSIONAL DRAWING

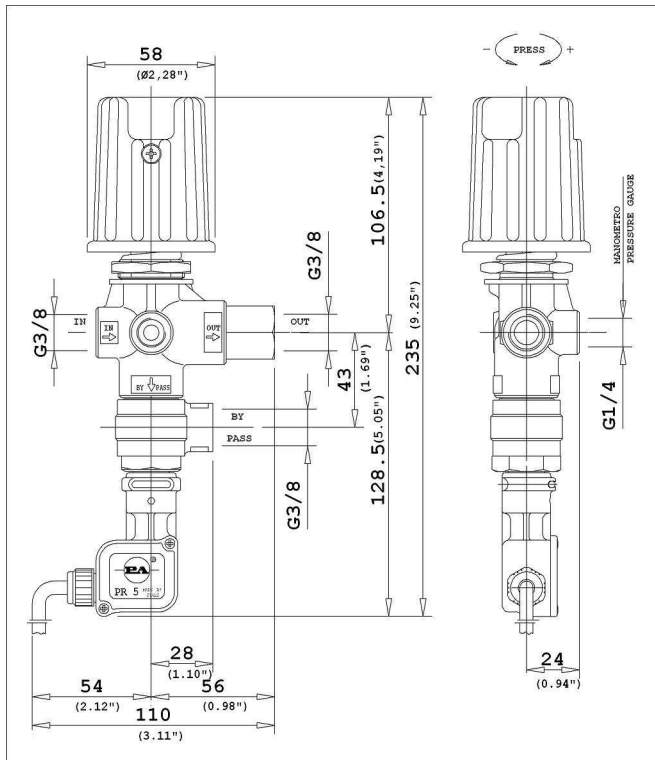

INSTRUCTIONS

SELECTION This product is to be utilized with clean fresh water, even slightly additivated with normal detergents. For use involving different or corrosive liquids, contact the PA Technical department. Appropriate filtration should be installed when using unclean liquids. Choose the valve in line with the data of nominal running (system rated pressure, max flow and max temperature). In any case, the pressure of the machine should not exceed the permissible pressure rate imprinted on the valve.

INSTALLATION

This accessory, on a system that produces hot water, must be fitted in **front of the heat generator**. This product is bound to be incorporated on a finished machine. On a system that generates hot water, anticipate the fitting of accessories that limit the accidental increase of fluid temperature.

Always install a safety valve that protects the pressurized inlet channel.

Choose a correct nozzle size, which allows a regular discharge on bypass, at least 5% of the total flow of the system in order to achieve a constant pressure value and avoid troublesome pressure spikes at closure. If the nozzle wears out, the pressure drops. On installation of a new nozzle, re-adjust the system to the original pressure setting. Electrical installation must be carried out by qualified personnel

ATTENTION: Always assure a correct earthing to this electric device

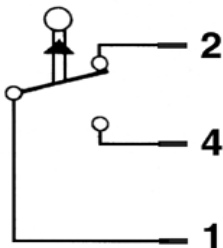

WIRING DIAGRAM

1) Red wire - 2) Blue wire - 4) Brown wire

ELECTRICAL CONNECTION

N.O. Red + Brown– Normally open
 N.C. Red + Blue – Normally closed

OPERATIONS

The valve regulates the max pressure of the system through a piston, which acts on a ball correctly positioned, that closes the bypass opening. A check valve cuts out the delivery section, the pressure of which controls the drive of the piston. Each regulation should be made when the system is operational and the nozzle open. In order not to overstep the max pressure, the nut pos.19 must be fastened securely. Mark the position with a drop of paint in order to prevent possible slackening and tampering. The balanced conformation of the valve allows a renewed pressure at very low readings giving a longer function in bypass and a progressive start, without unpleasant pressure spikes, useful with endothermic engines.

ATTENTION: In order not to overstep the max pressure, the nut (pos 41) must be fastened and never removed otherwise a mechanical safety feature would lack that limits the max pressure avoiding serious damage to persons and machine. For the min pressure position the locknut (pos 44) on the nut (pos 45) blocking it with a dowel (pos 43). Mark the position with a drop of paint in order to prevent possible slackening and tampering.

DISCHARGE SYSTEM AND WATER ADDUCTION

The bypass line should be returned into a tank with deflectors. By using a direct pump recycle, with elevated pressure intake, it is necessary to install a pressure reducer in order to have an even flow supply and to protect the circuit intake. When the system is opened and closed frequently, it is recommended to install a thermal protector valve (VT3 or VT6) in order to eliminate excessive temperature build-up. It is advisable to fit, for the bypass line direct to the pump, an appropriate sized hose of at least 250mm length.

PROBLEMS AND SOLUTIONS

PROBLEMS	PROBABLE CAUSES	SOLUTIONS
Frequent unloader recycles	Damaged check valve O ring Leaking connections Restricted bypass	Replace Check and renew Clean or adapt
Imperfect electric signal	Loose wires Short control pin	Reconnect Adjust nut and ball holder
Unloader does not reach pressure	Unloader not properly sized Piston O rings worn out Material matter between seat and shutter Worn out nozzle	Change spring or type of valve Replace Clean the seat Replace
Pressure peaks	There is not a min of 5% of total flow in bypass Excessive flow in bypass Spring totally compressed	Reset Change type of valve or adjust passages Loosen knob and change nozzle
Unloader does not bypass at low pressure	Jammed check valve Check valve O ring worn out Material matter on check valve	Clean or replace Replace Clean

REGULATIONS : *see norm manual*

The accessory hereby described bears the CE marking in accordance with the Norms and Directives applied on the Declaration of conformity.

For a correct utilization, follow the directions described in this manual and re-print them on the Use and maintenance manual of the machine.

Make sure that you are given **the Original Conformity Declaration** for the accessory chosen. The present manual is valid for all unloader valves named **VB 9 with micro switch**

MAINTENANCE

Maintenance has to be carried out by **Specialized Technicians**.

STANDARD: every 400 working hours (circa 10,000 cycles), check and lubricate the seals with water resistant grease.

SPECIAL: every 800 working hours(circa 20,000 cycles), control the wear of the seals and internal parts and if necessary, replace with original PA parts taking care during installation and to lubricate with water resistant grease.

ATTENTION: reassemble the valve in the correct manner paying special attention to the Nuts (pos 41) by fastening them with a drop of a strong glue.

The manufacturer is not to be considered responsible for damage as a result from incorrect fitting and maintenance

Technical data, descriptions and illustrations are indicative and liable to modification without notice.

60.2350.00 VB9 unload. 3/8F Bsp +el.sw.+knob

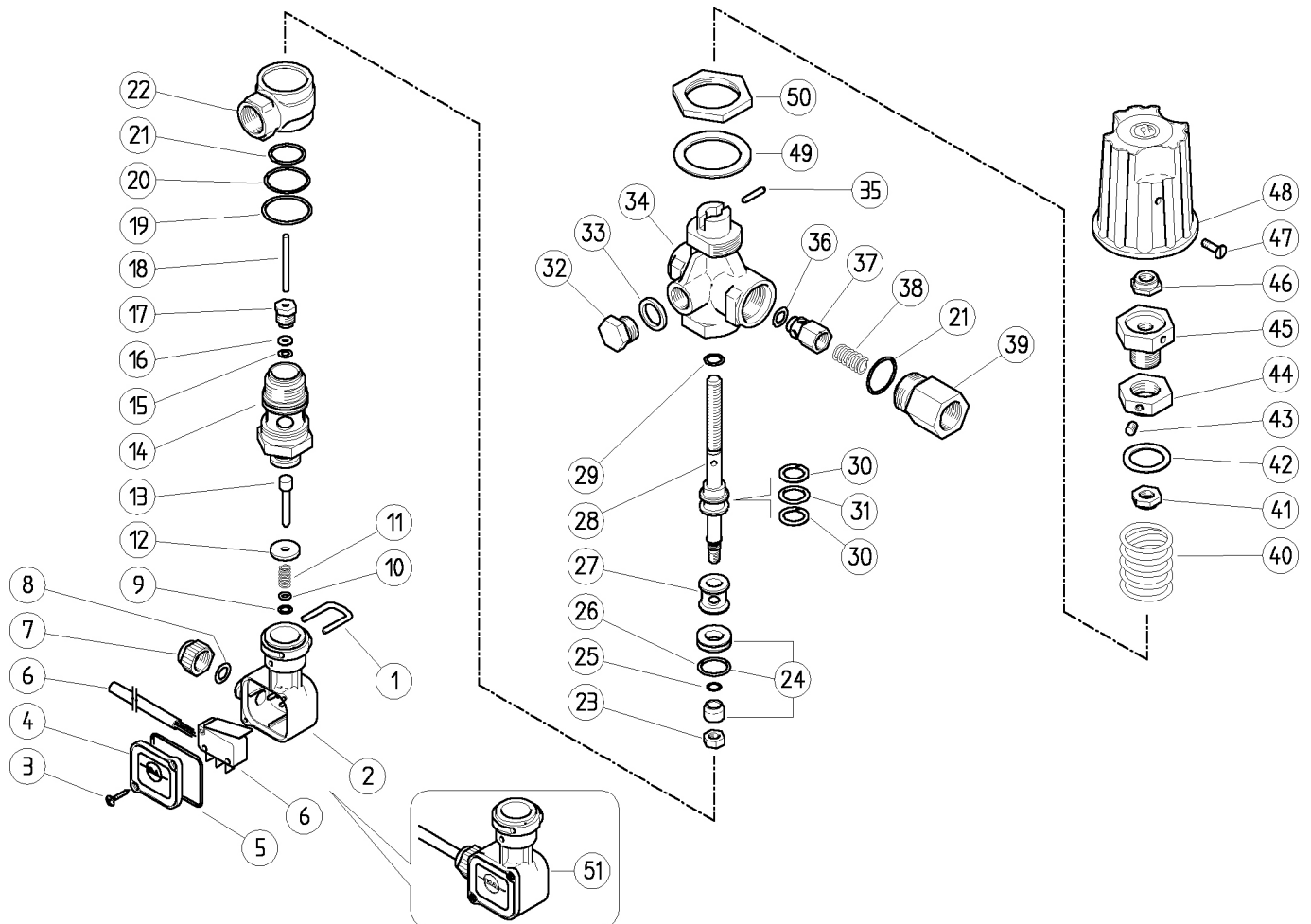

Pos.	P/N	Description	Q.ty	K1	K2	K3	K4	
1	29.0087.51	U-bolt, Sst.	1					10
2	29.0089.84	Housing, PR5 PA black	1					10
3	16.3020.00	S/tapp. screw, DIN7981 2,5x12mm nick.pl.	2					10
4	29.0088.84	Lid, PR5 PA black	1					10
5	10.3206.01	O-ring, 2,62x28,25 mm	1	•				10
6	12.5006.00	Cable, 3x0,75 L.1000 mm+ Microswitch	1					5
7	29.0109.84	Locknut for cable gland, PA red	1					10
8	10.3169.00	O-ring, 2,62x6,02 mm	1	•				10
9	10.3038.00	O-ring, 1,78x3,68 mm	1	•				10
10	14.3519.00	Washer, 4x8x0,5 mm brass	1					10
11	60.2303.51	Spring, 1,1x8x20 mm Sst.	1					10
12	29.0086.31	Washer, 4x16x2,5 mm brass	1					10
13	60.2351.31	Micro-switch piston, brass	1					10
14	60.2353.31	Seat holder, brass	1					3
15	10.3165.00	O-ring, 2,62x2,84 mm Vi 70	1	•				10
16	10.4018.00	Back-up ring, 3,2x7,5x1,2 mm	1	•				10
17	30.4115.31	Front Plug, M10x1 brass	1					10
18	60.2352.51	Parallel pin, 3x41mm Sst.	1					10
19	10.3073.00	O-ring, 1,78x23,52 mm	1	•				10
20	10.3072.50	O-ring, 1,78x21,95 mm	1	•				10
21	10.3070.02	O-ring, 1,78x18,77 mm Ni 85	2	•				10
22	60.0733.35	Valve manifold, brass	1					3
23	11.4540.00	Hex. nut, M6, Sst.	1					10
24	60.2221.20	Seat, 10mm+O-ring, 1,78mm NBR85+shutt.	1	•				3
25	10.3001.01	O-ring, 1x4 mm Ni 85	1	•				10
26	10.3066.01	O-ring, 1,78x15,6 mm Ni 85	1					10

Pos.	P/N	Description	Q.ty	K1	K2	K3	K4	
27	60.2210.31	Spacer ring, 8,5x16,8x14,5 mm brass	1					5
28	60.2202.51	Piston, M6-M8 Sst.	1					5
29	10.3170.08	O-ring, 2,62x7,6 mm Ni 85	1	•				10
30	10.4021.00	Back-up ring, opn. 11,5x15,9x1,2 mm	2	•				10
31	10.3175.00	O-ring, 2,62x10,77 mm	1	•				10
32	28.0013.31	Plug, brass 1/4 Bsp	1					25
33	14.3911.00	Washer, 13,5x19x1,5 mm Cu	1					10
34	60.2201.35	Housing -VB9, 3/8F-1/4F Bsp brass	1					5
35	15.1021.00	Roll pin, 3x14 mm Sst.	1					10
36	10.3213.00	O-ring, 3x6 mm	1	•				10
37	60.0052.31	Shutter pin, brass	1					10
38	60.0053.51	Spring, 0,7x9x20 mm Sst.	1					10
39	60.0058.31	Delivery coupl., 3/8F Bsp brass	1					5
40	60.2203.61	Spring, 4,2x27,4x31 mm z.pl.	1					10
41	60.2207.31	Ring nut, M8 brass	1					5
42	60.2208.84	Washer, 19x26x1,5 mm PA black	1					10
43	16.2105.00	Set screw, DIN913 M5x6 mm	1					10
44	60.2252.31	Ring nut, M16x1 brass	1					5
45	60.2253.31	Regulating pin, brass	1					10
46	11.4589.10	Hex. locknut, M8	1					10
47	16.1838.00	Screw, DIN7985 M4x10 mm z.pl.	1					10
48	60.2251.84	Valve regulating knob, PA black	1					5
49	14.3582.00	Washer, 30,5x42x2 mm	1					10
50	60.2254.31	Ring nut, M30 brass	1					10
51	29.0096.24	Casing kit -PR5, complete 40bar	1					50

Kit	P/N	Description	
K1	60.2355.24	Repair kit -VB9/01+PR5, 14x1pcs.	1